



City Council  
**Community Development Committee**  
**Thursday, July 20, 2017 at 10:00 am**  
**City Council Chambers**

1. INFORMATIONAL - REVIEW OF AVAILABLE FUNDS

Documents:

[AGENDA 2017 FUNDS 2018 BUDGETREVISED.PDF](#)

2. INFORMATIONAL - ATTORNEY MEMO ON CONSTITUTIONAL RESTRICTIONS

Documents:

[MEMO\\_CONSTITUTIONAL RESTRICTIONS.PDF](#)  
[NDAG 98-F-30.PDF](#)

3. APPLICATION REVIEW

3.I. CHILDREN'S MUSEUM OF MINOT, INC. (DBA MAGIC CITY DISCOVERY CENTER)  
AND MINOT PARK DISTRICT

The Magic City Discovery Center (MCDC) grew out of a brain storming session sponsored by the Minot Area Community Foundation. Through those discussions a dream and then a plan arose to create the Magic City Discovery Center. For the past three years the museum partnered with the Dakota Territory Air Museum which provided space for educational exhibits, creativity and play.

The Board plans on constructing a 20,000-square-foot building that is estimated to welcome 75,000 to 100,000 visitors per year, treating them to interactive STEAM (Science, Technology, Engineering, Art and Mathematics) based exhibits as well as outdoor exhibit space, educational classrooms and community multi-purpose space.

**The Magic City Discovery Center is requesting \$2.5 million toward an approximate \$10 million capital campaign fundraising effort.**

Documents:

[CHILDRENS MUSEUM.PDF](#)

3.II. CITY OF MINOT- CARNEGIE CENTER

The Carnegie Center was built in 1911 and is on the historical registry. The building

has been used in the past for many different functions and activities. Music lessons and recitals, art displays, weddings and receptions and also some historical displays. It has had very good interior care and the HVAC has been upgraded, all in compliance of the historical registry compliance guidelines.

The building has had some settling in one corner of the structure and action to correct this situation before the building can no longer be repaired or saved. The north wall from the west corner is sunk to the point where a large crack has developed from the top to the bottom separating brick and mortar, window ledges and window sills and decorative concrete trim and caps. Many windows themselves, jambs and storm windows which are holding the "poured" glass panels also need reselling. Once the building has been stabilized, point tuck work on the brick would need to be done.

**The City of Minot is requesting \$550,000 to include structural plans and design for the Carnegie Center repairs.**

Documents:

[CARNEGIE CENTER.PDF](#)

### 3.III. CITY OF MINOT- CITY HALL

The City of Minot is requesting Community Facility funding to make appropriate improvements to City Hall's Council Chambers to better serve people with disabilities in the community. Currently, Council Chambers is not completely in compliance with ADA standards. It does not aid any persons with hearing disabilities, and does not have appropriate access to the dais or podium for individuals with physical disabilities.

Funds requested will be used to help alleviate any physical barriers people with disabilities may face if they wish to participate in community meetings held in Council Chambers.

Among the physical upgrades will be technical upgrades that will allow people to watch any and all meetings from their home via online streaming and cable broadcast.

**The City of Minot is requesting \$70,000 to install physical and technical upgrades to the Council Chambers in City Hall.**

Documents:

[COUNCIL CHAMBERS.PDF](#)

### 3.IV. CITY OF MINOT- RECYCLING TRANSFER FACILITY

As we are currently rolling out automated trash collection, which was the first step toward implementing recycling, we are looking at the next phase of the ad committee recommendation to build a recycling transfer facility. Since the main goal of any recycling program is to

divert as much recyclable material as possible from the landfill, single stream recycling was the chosen method as it is proven to have the highest diversion rates. The drawback to single stream is that those materials need to be again separated into their individual commodities for marketing. Minot is located about 500 miles from the nearest materials recovery facility or MRF, thus the need for a transfer facility.

**The City of Minot is requesting approximately \$2.5 million for design and construction of a recycling transfer facility.**

Documents:

[RECYCLING FACILITY.PDF](#)

### 3.V. MINOT RECREATION COMMISSION- MUNICIPAL AUDITORIUM

The Minot Recreation Commission is requesting funds to replace the Auditorium Flooring in the Main Arena of the Municipal Auditorium, the existing tartan floor was installed in 1992. The Auditorium floor would be replaced with a similar type of tartan floor which would still allow for multiple events and athletic activities.

The Recreation/Auditorium is also requesting Community Funds to replace the remaining 543 light fixtures that have the T12 Bulb system. The lights were installed in 1992 during the last remodel and the T12 bulbs are no longer manufactured. The Auditorium has replaced many of the T12 lights during other remodeling projects and this phase would finish the remaining areas of the building that were not updated.

**The City of Minot and Minot Recreation Commission are requesting \$392,500 for Auditorium projects.**

Documents:

[AUDITORIUM.PDF](#)

### 3.VI. MINOT STATE UNIVERSITY

This request is for the replacement of seating in the MSU Dome on the Minot State University campus. The bleachers and chairs currently in the Dome represent the original seating installed in 1981 when the Dome was constructed. The purchase of new spectator seating will allow for safe and comfortable seating for those attending the many events held annually at the MSU Dome. Updated seating will also help attract additional events and new visitors to the facility and to the Minot community. The Dome provides seating for 10,000 spectators and is one of the largest arenas in the Upper Midwest.

**Minot State University is requesting \$2 million from the Community Facilities Fund for replacement seating in MSU Dome.**

Documents:

[MSU DOME.PDF](#)

3.VII. ROOSEVELT PARK ZOO/MINOT PARK DISTRICT

The total project cost is \$5 million dollars and consists of 3 separate projects: Amur Tiger habitat (\$1.9 million), African Lion habitat (\$2.1 million), and Cat complex for Amur leopards and Snow leopards (\$1 million). Both the tiger and lion habitats would be newly constructed exhibits featuring naturalistic landscapes for the enrichment of the animal as well as provide a dynamic and educational experience for our visitors. The cat complex would be a renovation of the existing habitat and will feature rock climbing structures and overhead catwalks to again provide an enriching home for the animals and unique visitor experience.

**The Roosevelt Park Zoo is requesting \$3 million dollars from the City's Facility Grant Fund to build new habitats for the big cats at Roosevelt Park Zoo.**

Documents:

[MINOT PARK DISTRICT.PDF](#)

3.VIII. SOURIS VALLEY ANIMAL SHELTER

The Souris Valley Animal Shelter (SVAS) has developed plans to remodel and expand to better suit the needs of the City of Minot and Ward County. The primary purpose of this expansion will focus on increasing our housing capabilities to reduce the number of feral/stray pets within the city of Minot and Ward County. This project will also include the addition of a spay/neuter clinic (the only clinic of its kind found WITHIN an animal shelter in North Dakota). The clinic will serve three purposes. The main purpose will focus on the SVAS's current pets. The next purpose is its Trap/Neuter/Release (TNR) program which focuses on sterilizing feral cats in our community to control reproduction. Finally, the SVAS will offer low income spay/neutering.

**The Souris Valley Animal Shelter is requesting \$900,000 in order to partially fund phase 1 of remodeling and expanding their facility.**

Documents:

[SOURIS VALLEY ANIMAL SHELTER.PDF](#)

3.IX. YWCA MINOT

YWCA Minot is located in a 3 story building, and can house 17 homeless women and children at a time. Currently, 5 of the 6 homeless shelter rooms are in the basement and the handicapped accessible room is on the main floor. The problem that we encounter when we house a handicapped client is that the shelters showering facility is on the basement level, and going down stairs can be hazardous or even impossible for a handicapped person. While we do have a restroom on the main floor, it is not equipped with the necessary features to serve our disabled clients. We hope to change that to better meet the needs of everyone who comes through our doors. With support, we intend to renovate the main floor restroom to include a handicapped accessible shower, a shower bench, and support rails.

**YWCA Minot is requesting \$5,000 to convert their main floor restroom into a handicapped accessible bathroom, and to create a new program called "Fresh Start."**



Documents:

[YWCA.PDF](#)

Date: July 11, 2017

To: Community Facility Committee

From: David Lakefield, Finance Director

Re: 2017/2018/Applications

The City of Minot has received nine applications for consideration by the Community Facility Committee. However, before a summary of the applications is provided a recap of the Community Facility Fund may be beneficial to the Committee.

The City of Minot has collected \$21,123,737 through May 2017. The 2017 collections are down approximately 8 percent from last year. The following table lists the projects that have been funded using Community Facilities Funds in prior years.

Project	Project No.	Year	Approved	Spent	Remaining
Corbett & Hoeven Field Sod	ST2P01	2012	\$ 250,000.00	\$ 250,000.00	\$ -
Dakota Territorial Air Museum	ST2P04	2013	500,000	500,000	-
MSU Herb Parker	ST2P06	2012	4,000,000	4,000,000	-
Park District Flood Control	ST2P07	2012	1,700,000	1,700,000	-
BRCS Gym Improvement	ST2P09	2013	275,000	275,000	-
Minot Commission on Agin	ST2P10	2013	400,000	400,000	-
NDSF Curling	ST2P11	2013	275,000	275,000	-
YMCA Outdoor	ST2P12	2013	193,585	193,585	-
MAYSA Ice	ST2P13	2013/2016	4,000,000	4,000,000	-
Hammond Park	ST2P14	2013	500,000	493,879	<b>6,121</b>
Softball	ST2P15	2013	257,776	257,776	-
Minot Rec Perkett Skating	CAP003	2012/2015	587,440	461,327	<b>126,113</b>
Armory Roof		2013	100,000	66,667	<b>33,333</b>
MSU Multisport Dome	ST2P17	2016	1,000,000	1,000,000	-
Sport Complex Paving	REC023	2016	1,000,000	634,629	<b>365,371</b>
Jack Hoeven Field Improvement	ST2P16	2016	1,000,000	-	1,000,000
South Hill Complex Synthetic Turf Installation	ST2P18	2017	2,000,000	-	2,000,000
Minot Commission on Aging Office Remodel	ST2P19	2017	135,000	135,000	-
Domestic Violence Crisis Center	ST2P20	2017	100,000	100,000	-
Administration			300,000	300,000	-
			\$ 18,573,800.96	\$ 15,042,862.30	\$ 3,530,938.66
Bold items - funds added back to available funds					

The funds available to award are as follows:

Summary of Funds				
Collections Through April 2017	\$	21,123,737		
Anticipated Collections May-Dec.	\$	1,490,805		
Approved	\$	(18,316,025)		
Add back Funds Returned	\$	530,939	*Bolded items from 'Funded Projects' tab	
<b>Available to Award</b>	<b>\$</b>	<b>4,829,456</b>		

Pursuant to Ordinance No. 4380 of the Minot Code of Ordinances, the City of Minot may make proceeds available from the city sales tax for purposes of upgrading, remodeling and constructing community facilities. These community facilities, include but are not limited to, arenas, auditoriums, and facilities for conventions. In 2014, an ad hoc committee presented the following definition for “community facility” which was approved by the City Council: “A Community Facility would fill a need by the community, and it should be owned and operated by a political subdivision. If non-profit groups are eligible, they should be limited to partnership projects with political subdivisions, not stand alone non-profit projects. Local control and community benefit is required.” Since the approval of the definition, the City Council has approved projects for community facilities owned by the City; for community facilities owned by other political subdivisions or state entities; and for community facilities owned by private non-profit entities when the entity has applied with a political subdivision partner.

The following is a summary of the applications (taken directly from the application), in no specific order. Please refer to the application for additional details. A copy of the complete application is attached as well as a memo from the City Attorney regarding the award of Community Facility Funds.

**1. Municipal Auditorium – City of Minot**

This project would replace the existing tartan floor in the Main Arena of the Municipal Auditorium. This floor was originally installed in 1992 and would be replaced with a similar type of tartan floor. The project would also replace the remaining 543 light fixtures that have the T12 bulb system with High Efficient LED Lights.

\$175,000— Auditorium Arena Flooring

\$ 50,000 — Auditorium Arena Removal

\$ 10,000 — Engineering Costs

\$235,000

\$150,000 — Auditorium Complex LED Light Fixture Replacement (T12 Fixtures)

\$ 7,500 — Engineering Costs

\$157,500

**\$392,500 - Total Amount Requested for Auditorium Projects**

**2. Council Chambers Upgrades – City of Minot**

Brief Scope of Improvements: (Expanded information attached)

- A. A ramp to the dais will be constructed on the north wall and designed to blend with the existing interior design of the room.
- B. A custom podium will be built to allow individuals who may be wheelchair bound the ability to speak into the microphone.
- C. The podium will be equipped with a document projector for individuals who have brought supplemental documents they wish to share. This will allow everyone to see what is being discussed if copies were not supplied for the room. Among the physical upgrades will be technical upgrades that will allow people to watch any and all meetings from their home via online streaming and cable broadcast.

Specific amounts requested from the City of Minot and dates requested:

\$45,000— A/v Upgrades and Installation  
 \$15,000— ADA Compliant Wheelchair Ramp  
 \$ 3,500— Mid.co Digital Broadcast Equipment  
 \$ 3,000 — Contingency Overruns\* \$ 2,000— ADA Compliant Custom Podium  
~~\$ 1,500-~~ Dell Precision Work Station Mini Tower CPU  
 \$70,000- TOTAL

### 3. **Roosevelt Zoo – Minot Park District (political subdivision)**

#### Project Summary

We are requesting \$3 million dollars from the City’s Facility Grant Fund to build new habitats for the big cats at Roosevelt Park Zoo. The total project cost is \$5 million dollars and consists of 3 separate projects: Amur Tiger habitat (\$1.9 million), African Lion habitat (\$2.1 million), and Cat complex for Amur leopards and Snow leopards (\$1 million). Both the tiger and lion habitats would be newly constructed exhibits featuring naturalistic landscapes for the enrichment of the animal as well as provide a dynamic and educational experience for our visitors. The cat complex would be a renovation of the existing habitat and will feature rock climbing structures and overhead catwalks to again provide an enriching home for the animals and unique visitor experience.

#### Project Description

The Minot Park District and Minot Zoo Crew are partnering to improve our zoo with major capital investments. We look back on our history as inspiration to guide our future. Prior to the 2011 flood, we had master plan goals to address aged infrastructure. Our focus was on exhibits built in the 1970s following the devastation of the 1969 flood namely: our cat complex, bear den and primate exhibits. These exhibits are antiquated and no longer meet modern zoological standards in terms of design and theory. These projects would improve our animals’ quality of life and welfare. The project would provide larger, naturalistic and enriching habitats to encourage natural behavior of the animals and meet their species specific needs. Modern zoo theory and design not only

addresses the component of animal welfare but, also the visitor experience. Zoo visitors will gain understanding and appreciation of the animals who serve as ambassadors for their wild counterparts. We will work to further our visitor's understanding with educational signage highlighting habitat awareness and conservation initiatives to help save animals from extinction.

4. **YWCA Minot – Private Non-Profit Organization (No Political Subdivision Partner Provided)**

YWCA is seeking funding to convert our main floor restroom into a handicapped accessible bathroom, and to create a new program called "Fresh Start."

YWCA Minot is located in a 3 story building, and can house 17 homeless women and children at a time. Currently, 5 of our 6 homeless shelter rooms are in our basement and our handicapped accessible room is on the main floor. The problem that we encounter when we house a handicapped client is that the shelters showering facility is on the basement level, and going down stairs can be hazardous or even impossible for a handicapped person. While we do have a restroom on the main floor, it is not equipped with the necessary features to serve our disabled clients. We hope to change that to better meet the needs of everyone who comes through our doors. With support, we intend to renovate the main floor restroom to include a handicapped accessible shower, a shower bench, and support rails.

In addition to this upgrade improving the lives of our handicapped clients, it will also be an opportunity to extend our community outreach. YWCA Minot is a zero-tolerance drug and alcohol shelter. If a person has any illegal substances in their system, they are not permitted to stay at the shelter until they are clean. While we do this to protect our clients, we recognize that these women and children need help too. That is why we intend to open our doors to the women and children in the Minot community during business hours to allow them to take a shower, meet with our staff, and get access to toiletries and clothing. This new service has been named the "Fresh Start" program. This is because we believe that simply being freshly showered may enable some of these women to pick up their lives, find jobs, and be a more marketable person in the community. Everyone deserves a "fresh start."

Because of the age of the building and the fact that we will have to re-work the layout of the restroom, we expect to pay up to \$14,000 dollars. It is our hope that we can stay closer to \$10,000. This number includes a new handicap accessible shower with accessories (safety bars and shower seats as necessary), plumbing changes, potential building related issues, and contractor fees. It is our goal to complete the project in the 2017 year, but understand that it may take longer.

5. **MSU Dome – State Board of Higher Education (State Entity)**

This request is for the replacement of seating in the MSU Dome on the Minot State University campus. The bleachers and chairs currently in the Dome represent the original seating installed in 1981 when the Dome was constructed. The purchase of new spectator

seating will allow for safe and comfortable seating for those attending the many events held annually at the MSU Dome. Updated seating will also help attract additional events and new visitors to the facility and to the Minot community. The Dome provides seating for 10,000 spectators and is one of the largest arenas in the Upper Midwest.

This request will help ensure the Minot community has a facility that provides an outstanding environment for the thousands who come to the Dome every year. Seating is vital to the comfort and overall experience for spectators, thus setting the stage for Minot to realize a positive economic impact through continued and increased attendance at Dome events. Events at the MSU Dome lead directly to an increase in lodging tax revenue, retail sales, and food/beverage sales in Minot. In addition to this increased economic impact is a quality of life enhancement for area citizens due to the many events held annually at the Dome. Other similar facilities in North Dakota are constantly upgrading their amenities, and we must do so to remain competitive and continue attracting major events to our community.

The total cost of new seating and installation is \$2 million. MSU is requesting \$2 million from the Community Facilities Fund. If funds are realized through this request, construction could begin in spring 2018 with substantial completion by August 2018.

**6. Souris Valley Animal Shelter – Private Non-Profit Organization (No Political Subdivision Partner Provided)**

The Souris Valley Animal Shelter (SVAS) has developed plans to remodel and expand to better suit the needs of the City of Minot and Ward County. The primary purpose of this expansion will focus on increasing our housing capabilities to reduce the number of feral/stray pets within the city of Minot and Ward County. This project will also include the addition of a spay/neuter clinic (the only clinic of its kind found WITHIN an animal shelter in North Dakota). The clinic will serve three purposes. The main purpose will focus on the SVAS's current pets. The next purpose is its Trap/Neuter/Release (TNR) program which focuses on sterilizing feral cats in our community to control reproduction. Finally, the SVAS will offer low income spay/neutering.

The addition of a 44'X34' multi-purpose room will enable the SVAS to expand the capacity of care in times of crisis for both the City and citizens in need of emergency sheltering. Additionally, the room will allow us to expand our community programs. The introduction of programs such as therapy dogs, emergency sheltering, humane education, and the "Read to the Animals" program have been very well received in the community. The therapy dog program partners with the Domestic Violence Crisis Center, the YWCA, the Men's Winter Refuge, and most assisted living facilities and retirement homes in the Minot community. Pre-screened animals are brought to scheduled destinations to allow residents an hour to interact with the SVAS pets. This gives the pets much needed socialization and exercise while at the same time providing comfort to the most vulnerable.

The project will consist of 2 separate phases. Phase 1 will be the addition of nearly 7,000 square feet on the back of our property. This phase will include a 44'X34' multi-purpose

room, overflow housing, upgraded mechanical rooms, the separation of cats and dogs, a dog daycare/groomer (this area will provide funding for the spay/neuter clinic) and an after-hours surrender area. Phase 2 will remodel the existing building to better utilize space. This remodel will include the addition of the Spay/Neuter Clinic, better drainage, better air circulation, additional adoption /Read to the Animals rooms.

Amount requested is \$900,000 in order to partially fund Phase 1; Date requested is January 15, 2018.

## **7. Recycling Facility – City of Minot**

Due to a high volume of requests from citizens of Minot. a presentation was given to the Minot City Council outlining what a recycling program could look like and what steps the City would need to take to get a recycling program off the ground. Following this presentation, a recycling ad hoc committee was formed to work through the issues and hurdles of a recycling program. After the committee researched and studied recycling for about 4 months a recommendation was made to the City Council that a recycling program would be a benefit to the City of Minot and moves should be made to implement one.

As we are currently rolling out automated trash collection, which was the first step toward implementing recycling, we are looking at the next phase of the ad committee recommendation to build a recycling transfer facility. Since the main goal of any recycling program is to divert as much recyclable material as possible from the landfill, single stream recycling was the chosen method as it is proven to have the highest diversion rates. The drawback to single stream is that those materials need to be again separated into their individual commodities for marketing. Minot is located about 500 miles from the nearest materials recovery facility or MRF, thus the need for a transfer facility.

The addition of a transfer facility will not only benefit the City of Minot, but it will benefit the region. Minot Municipal Landfill is a regional landfill that accepts waste from 7 different counties. Annually, nearly 80,000 tons of municipal solid waste is disposed of in the Minot Landfill. Over half of this volume is coming in from surrounding communities in the region. While a well-run recycling program in Minot could divert thousands of tons of waste from the landfill, the City can only affect what is generated within our community. By building a transfer facility, recycling is made available to the region and many communities have already expressed interest in implementing their own recycling program including the Minot Air Force Base.

Design and Construction is estimated to cost approximately \$2.5 million. In order to get the facility completed by early 2019, funding is requested for October of 2017.

## 8. Carnegie Center – City of Minot

The Carnegie Center was built in 1911 and is on the historical registry. The building has been used in the past for many different functions and activities. Music lessons and recitals, art displays, weddings and receptions and also some historical displays. It has had very good interior care and the HVAC has been upgraded, all in compliance of the historical registry compliance guidelines.

The building has had some settling in one corner of the structure and action to correct this situation before the building can no longer be repaired or saved. The north wall from the west corner is sunk to the point where a large crack has developed from the top to the bottom separating brick and mortar, window ledges and window sills and decorative concrete trim and caps. Many windows themselves, jambs and storm windows which are holding the “poured”

glass panels also need reselling. Once the building has been stabilized, point tuck work on the brick would need to be done. A project timeline would all determined after a structural engineer could determine the extent of the work needed to stabilize the structure and complete all the repairs needed to stay in compliance with the Historical Registry criteria.

Specific amounts requested from the City of Minot and dates requested:  
\$550,000 to include structural plans and design.

## 9. Children’s Museum of Minot – Private Non-Profit Organization with Minot Park District Partnership

The Magic City Discovery Center (MCDC) grew out of a brain storming session sponsored by the Minot Area Community Foundation. Through those discussions a dream and then a plan arose to create the Magic City Discovery Center. For the past three years the museum partnered with the Dakota Territory Air Museum which provided space for educational exhibits, creativity and play.

The Board plans on constructing a 20,000-square-foot building that is estimated to welcome 75,000 to 100,000 visitors per year, treating them to interactive STEAM (Science, Technology, Engineering, Art and Mathematics) based exhibits as well as outdoor exhibit space, educational classrooms and community multi-purpose space. The board reached an agreement with the Minot Park District Board in late June that would allow MCDC to build on North Hill park district land. The site is visible from Broadway and provides a beautiful panoramic view of Minot. MCDC plans to open a hybrid (children’s and science) museum that serves children from birth to age 14. Community feedback confirms the need for this incomparable educational experience and unique regional destination.

The Magic City Discovery Center is asking for \$2.5 million toward an approximate \$10 million capital campaign fundraising effort. Should this be the lead gift for the children’s



museum, the name would remain as is, to continue to honor the magical heritage that is a part of Minot's rich history. This funding would be needed in 2018 for excavation, foundation and other work associated with the new building.

The complete applications are attached for your review. The Finance Department will be available to answer any questions in regards to the fund available for distribution.

# City of Minot

## City Attorney's Office

### MEMORANDUM

**TO:** Mayor and City Council  
**FROM:** Kelly Hendershot  
**RE:** Community Facilities  
**DATE:**

In 2011, the citizens of Minot voted to temporarily reallocate the second penny (the “NAWS Penny”). Thirty percent of the NAWS Penny was approved to go towards community facilities. No definition of “community facility” existed from 2011 through 2014. In 2014, the City Council appointed an ad hoc committee to define “community facility.” The ad hoc committee drafted the following definition, which was approved on June 2, 2014 by the full City Council:

A community facility would fill a need by the community, and it should be owned and operated by a political subdivision. If non-profit groups are to be eligible, they should be limited to partnership projects with political subdivisions, not stand alone non-profit projects. Local control is the main concern on any project funded, and true benefit to the community.

A review of prior City Council decisions relating to community facilities and of the discussions at the ad hoc committee reveals that the reason for this requirements is to ensure the City does not violate any constitutional provisions relating to donating public funds to private organizations.

Article X, Section 18 of the North Dakota Constitution provides:

The state, any county or city may make internal improvements and may engage in any industry, enterprise or business, . . . but neither the state nor any political subdivision thereof shall otherwise loan or give its credit or make donations to or in aid of any individual, association or corporation except for reasonable support of the poor, nor subscribe to or become the owner of capital stock in any association or corporation.

In North Dakota Attorney General Opinion 98-F-30 (attached to this memorandum), the Attorney General considered whether the City of Minot could constitutionally donate a sum of money to the YMCA, to defray part of the costs of constructing a new building to house the YMCA’s offices and operations. There, the Attorney General stated that it would be a violation of the North Dakota Constitution (Article X, Section 18) for the City to donate money for construction of a new YMCA building, unless the donation were made in connection with an enterprise pursuant to the City’s home rule charter and an implementing ordinance detailed to ensure the donation has a public purpose and the public purpose is met.

The Attorney General provided that the limitations of Article X, Section 18 do not apply in three situations: (1) when money is used to make internal improvements; (2) when money is donated to the poor; and (3) when money is distributed to an authorized industry, enterprise, or business of the city.

The Attorney General opined that a donation to a private entity to house a private association does not constitute an “internal improvement.” Further, the Attorney General indicated that the donation to the poor exception was inapplicable because the project did not constitute a donation “for reasonable support of the poor.” In conjunction with that analysis, the Attorney General stated that “[s]imply asserting that a donation to a private entity is for the reasonable support of the poor is not a sufficient basis for which to make such a donation.” With that, the Attorney General determined that the City could not donate money to the YMCA under that exception.

As indicated above, the Attorney General did determine the City could donate money to the YMCA if the donation were pursuant to an authorized industry, enterprise, or business of the city. The Attorney General provided that an enterprise is an activity which does not violate the North Dakota Constitution or statutes and which is of some scope, complication or risk. In order for the City to engage in an enterprise, it must have an implementing ordinance that (1) authorizes the City to engage in the proposed enterprise; (2) provides assurance that the activity has a public purpose; (3) sufficiently details the manner of implementing the activity; and (4) provides for supervisory controls to ensure the public purpose is met.

Under the YMCA scenario, the Attorney General suggested two examples of appropriate enterprises: (1) if the City provided a physical fitness program for its citizens and then contracted with the YMCA for services relating to the physical fitness program; and (2) if the City developed a grant program to provide funds to organizations for promoting the health and welfare of Minot’s citizens with specific application criteria.

With regard to the community facility applications before the City Council at this time, it is important for the City Council to (1) consider the definition of “community facility” in conjunction with determining which projects to move forward; and (2) if the City Council determines that an eligible private non-profit application should be approved, that the City Council determine (a) determine what enterprise the City is engaging in with the private non-profit organization; and (b) determine the essential elements of the implementing ordinance: (i) the City is authorized to engage in the proposed enterprise; (ii) public purpose of the activity; (iii) details on implementation of the activity; and (iv) supervisory controls to ensure the public purpose is met.

Among other things, the definition of “community facility” specifically requires that any private non-profit organization applying for funding must be partnered with a political subdivision. It should be noted that the definition provided by the ad hoc committee and approved by the full City Council in 2014 is not incorporated into our city ordinance and is not binding. However, the City Council has previously denied applications since the approval of the definition, on the basis that a private non-profit organization applied for funding without a political subdivision partnership (e.g., DVCC 2015 application).

To be clear, the requirement for an enterprise is only if the City is donating public money to a private organization. This requirements does not apply to money provided to City projects or to projects pursued directly with other political subdivisions or state entities; in projects with other political subdivisions or state entities, the City can enter into joint powers agreements pursuant to section 54-40.3-01 of the North Dakota Century Code.

STATE OF NORTH DAKOTA

ATTORNEY GENERAL'S OPINION 98-F-30

Date Issued: December 17, 1998

Requested by: Representative Ben Tollefson

- QUESTION PRESENTED -

Whether the city of Minot, a home rule city, constitutionally may donate a sum of money to the Young Men's Christian Association (YMCA) to be used by the YMCA to defray part of the costs of constructing a new building to house the Association's offices and operations.

- ATTORNEY GENERAL'S OPINION -

It is my opinion that it is a violation of Article X, Section 18 of the North Dakota Constitution for a home rule city to donate funds for construction of a new YMCA building unless the donation is made in connection with an enterprise authorized by the city's home rule charter and an implementing ordinance sufficiently detailed to ensure the donation has a public purpose and the public purpose is met.

- ANALYSIS -

The YMCA is a private organization. The information accompanying the request for an opinion states that the mission of the YMCA is "[t]o put Christian principles into practice through programs that build healthy spirit, mind, and body for all." The YMCA provides facilities in the community for people of both sexes to engage in sporting, recreational, and athletic activities.

The constitutional authority of the state, county, or city to donate funds to a private corporation was summarized in a 1993 Attorney General's opinion as follows:

The use of public funds is restricted by a number of state and federal constitutional provisions including Article X, Section 18 of the North Dakota Constitution, the Fourteenth Amendment of the United States Constitution and its North Dakota counterpart, Article I, Section 16.

Article X, Section 18 of the North Dakota Constitution provides:

The state, any county or city may make internal improvements and may engage in any industry, enterprise or business, . . . but neither the state nor any political subdivision thereof shall otherwise loan or give its credit or make donations to or in aid of any individual, association or corporation except for reasonable support of the poor, nor subscribe to or become the owner of capital stock in any association or corporation.

The North Dakota Supreme Court has construed Article X, Section 18 as not prohibiting a state or political subdivision from loaning or giving its credit or making donations in connection with the state or political subdivision's operation of any authorized industry, enterprise, or business. Gripentrog v. City of Wahpeton, 126 N.W.2d 230, 237-38 (N.D. 1964). Rather, what it does prohibit is for the state or political subdivision to "otherwise" loan or give its credit or make donations. Id. . . .

Under the Fourteenth Amendment of the United States Constitution, a state may not "deprive any person of life, liberty or property without due process of law." North Dakota's constitution contains a similar provision in Article I, Section 16. Under these constitutional provisions, a state may expend public funds only for public purposes. Green v. Frasier, 253 U.S. 233 (1920). The legality of a given expenditure under these two due process constitutional provisions thus turns on whether it is primarily for a private or public purpose.

"A public purpose or business has for its objective the promotion of the public health, safety, morals, general welfare, security, prosperity and contentment of all the inhabitants or residents within a given political subdivision." Gripentrog v. City of Wahpeton, 126 N.W.2d 230 at 237, (N.D. 1964) quoting Green v. Frasier, 176 N.W. 11 (N.D. 1920) affirmed 253 U.S. 233. Although each case is dependent upon its own unique facts and circumstances, courts will generally defer to a legislative determination

December 17, 1998

Page 3

that a particular expenditure will promote the public welfare. Green v. Frasier, 253 U.S. 233.

1993 N.D. Op. Att'y Gen. L-313, L-314 to L-315 (Nov. 3 letter to Allen Kopyy). Thus, the limitations of Article X, Section 18 of the North Dakota Constitution do not apply in three situations: (1) when the money is used to make internal improvements; (2) when the money is donated for the support of the poor; or (3) when the money is distributed pursuant to an authorized industry, enterprise, or business of the city.

As stated, a city may use its money to make internal improvements. The term "internal improvements" is not defined by the North Dakota Constitution or North Dakota statutes. Further, there are no North Dakota decisions defining the term "internal improvements."

In the absence of a statutory definition, words are to be given their plain and ordinary meaning. N.D.C.C. § 1-02-02; Kim-Go v. J.P. Furlong Enterprises, Inc., 460 N.W.2d 694, 696 (N.D. 1990). Black's Law Dictionary defines "internal improvements" as follows:

With reference to governmental policy and constitutional provisions restricting taxation or the contracting of public debts, this term means works of general public utility or advantage, designed to promote facility of intercommunication, trade, and commerce, the transportation of persons and property, or the development of the natural resources of the state, such as railroads, public highways, turnpikes, and canals, bridges, the improvement of rivers and harbors, systems of artificial irrigation, and the improvement of water powers; but it does not include the building and maintenance of state institutions.

Black's Law Dictionary, 816 (6th ed. 1990). The history of Article X, Section 18 supports the above understanding of the term internal improvements. See Northwestern Bell Telephone Co. v. Wentz, 103 N.W.2d 245, 252 (N.D. 1960). Based upon the generally understood meaning of the term "internal improvement," it is my opinion that a city's donation of money for the construction of a building by a private entity to house a private association does not constitute an "internal improvement."

A city may also give donations for the support of the poor without engaging in an industry, business, or enterprise under Article X, Section 18 of the North Dakota Constitution. Donating money to the

YMCA to be used by the YMCA to defer part of the cost of constructing a new building does not constitute a donation "for reasonable support of the poor." Furthermore, Article VII, Section 2 of the North Dakota Constitution requires specific statutory authority, or a statute from which that authority can necessarily be implied, before a donation can be made. Simply asserting that a donation to a private entity is for the reasonable support of the poor is not a sufficient basis by which to make such a donation. See Letter from Attorney General Nicholas J. Spaeth to Charles R. Isakson (Sept. 29, 1992). Accordingly, from my review of the facts available, it is my opinion that Minot may not donate money to the YMCA under the exception regarding donations for the support of the poor.

A city, however, could constitutionally donate money to a YMCA if the donation were pursuant to an authorized industry, enterprise, or business of the city. The city of Minot is a home rule city. N.D.C.C. chapter 40-05.1 provides for home rule authority in cities. Under this chapter, a city may enact ordinances in matters of local concern that fall within the powers enumerated in N.D.C.C. § 40-05.1-06 if such powers are included in the city's home rule charter.

A home rule city may be authorized in its home rule charter to "engage in any utility, business, or enterprise permitted by the constitution or not prohibited by statute." N.D.C.C. § 40-05.1-06(10). If a home rule city wants to engage in an enterprise not authorized by statute, it must have such authorization in its charter, and the proposed enterprise must be implemented through an ordinance. N.D.C.C. §§ 40-05.01-06, 40-05.1-06(10).

1993 N.D. Op. Att'y Gen. 40, 40-41.

The home rule charter for the city of Minot authorizes the city to "engage in any utility or enterprise permitted by the constitution or not prohibited by statute . . . ." Home Rule Charter, City of Minot, Art. 3, sec. j (1972). No statute prohibits a home rule city from creating an enterprise through which the city could provide funds for the use of a private organization. Thus, it is necessary to determine whether a city's provision of funds for the use of a private organization such as the YMCA constitutes an enterprise. See 1993 N.D. Op. Att'y Gen. 40.

"[T]he term 'enterprise' means any activity which does not violate the North Dakota Constitution or statutes and which is of some scope, complication, or risk." Id. at 42. Participating in a program to

provide funds for the use of a private organization such as the YMCA is of some scope, complication, or risk and, therefore, would constitute a permissible enterprise if done appropriately.

Two examples of types of possible enterprises Minot could create for providing the type of support it proposes for the Minot YMCA are as follows. First, Minot could establish an enterprise to provide a physical fitness program for its citizens. Minot, through its enterprise, could contract with a third party, such as the YMCA, for the provision of services under that program.

A second example of an enterprise Minot could create would involve developing a grant program to provide funds to organizations for promoting the health and welfare of Minot's citizens. The grant program would necessarily need specific application criteria. If an applicant, such as the YMCA, met those criteria, the city could provide funding for the applicant's provision of services promoting the citizens' health and welfare. Minot's establishment of either type of these programs may be a permissible enterprise.

In its attempt to create a permissible enterprise, Minot should realize there are several restrictions on an enterprise's purpose and structure. This office has previously explained that "[a] city may not engage in an enterprise unless it is for a public purpose." 1993 N.D. Op. Att'y Gen. 40, 42. Furthermore, "[a]n ordinance permitting a home rule city to engage in a particular enterprise must provide for supervisory controls to ensure that the public purpose is met." Id. The implementing ordinance must also "be sufficiently detailed so that the public is properly informed of the authority and limits of the enterprise." Id.

Thus, it is my opinion that a home rule city whose home rule charter authorizes it to enter into enterprises may engage in an enterprise whereby the city participates in a program to provide funds for the use of a private organization, such as the YMCA, if the implementing ordinance: "(1) authorizes the city to engage in the proposed enterprise, (2) provides assurance that the activity has a public purpose, (3) sufficiently details the manner of implementing the activity, and (4) provides for supervisory controls to ensure the public purpose is met." See 1993 N.D. Op. Att'y Gen. 40, 42-43. The city of Minot has not identified an implementing ordinance creating an enterprise through which a sum of money could be donated to the YMCA. Absent an appropriate implementing ordinance, the city of Minot would not have an enterprise through which it could constitutionally donate funds to the YMCA.



In conclusion, a strong argument exists that contributing funds to the YMCA constitutes a public purpose. It is not, however, done for the reasonable support of the poor. Construction of a building to house the YMCA's offices and organization also does not constitute an "internal improvement" as that phrase is used in Article X, Section 18. Accordingly, it would be a violation of Article X, Section 18 of the North Dakota Constitution for the city of Minot to donate to the YMCA funds for construction of a new YMCA building, unless the donation were made in connection with an enterprise pursuant to the city's charter and an implementing ordinance sufficiently detailed to ensure the donation has a public purpose and the public purpose is met. See generally 1998 N.D. Op. Att'y Gen. 116 (the state may not donate money to the nonprofit foundation entitled Women in Military Service for American Memorial Foundations); 1993 N.D. Op. Att'y Gen. L-313 (the Department of Veterans Affairs may not make a donation to assist a private veterans organization); 1993 N.D. Op. Att'y Gen. L-292 (using revenues from the city sales tax to reduce individual property taxes would have the effect of transferring to property owners moneys held for all the people of the city and violate Article X, Section 18); 1985 N.D. Op. Att'y Gen. 43 ("[A] city may not contribute money to a private nonprofit corporation in order to assist the corporation in constructing the civic facility that the city will not own or control."); Letter from Attorney General Nicholas Spaeth to Kidder County State's Attorney Jerry Renner (Aug. 19, 1985) (a city park board cannot expend public monies to assist a nonprofit corporation in operating a swimming pool); 1968-1970 N.D. Op. Att'y Gen. 92 (a county may not contribute to a worthwhile county project); 1968-1970 N.D. Op. Att'y Gen. 507 (townships may not make donations to entities such as the Red Cross or American Cancer Society); Solberg v. State Treasurer, 53 N.W.2d 49 (N.D. 1952) (a state transfer of a 50% mineral interest reserved in property without consideration would be an unconstitutional gift); Herr v. Rudolf, 25 N.W.2d 916 (N.D. 1947) (a transaction involving the sale of state owned property for less than what could be obtained for the property violates Article X, Section 18).

- EFFECT -

This opinion is issued pursuant to N.D.C.C. § 54-12-01. It governs the actions of public officials until such time as the question presented is decided by the courts.

ATTORNEY GENERAL'S OPINION 98-30  
December 17, 1998  
Page 7

Heidi Heitkamp  
Attorney General

Assisted by: Douglas A. Bahr  
Assistant Attorney General

Scott A. Miller  
Assistant Attorney General

vjk

COMMUNITY DEVELOPMENT COMMITTEE APPLICATION AND REQUEST FORM  
FOR USE OF SALES TAX PROCEEDS FOR

COMMUNITY FACILITIES

INTRODUCTION

Pursuant to Ordinance No. 4380 of the Minot Code of Ordinances, the City of Minot may make proceeds available from the city sales tax for purposes of upgrading, remodeling and constructing community facilities. These community facilities, for example, may be constituted by arenas, auditoriums, and facilities for conventions, tourist and sporting events. Community facilities must meet one of the following three categories in order to be eligible for possible funding: (1) community facilities owned directly by the City of Minot; (2) community facilities owned directly by another county, city, township, city park district, school district, or other political subdivision of the state of North Dakota, including any agency, board, or institution of the state of North Dakota, and for which entities an appropriate Joint Powers Agreement has been lawfully executed between the City of Minot and the applicable entity; and (3) community facilities of private non-profit entities with which the City of Minot has authority to engage in with respect to a lawful business or enterprise under North Dakota law meeting a public purpose and for which an independent and applicable implementing Ordinance has been passed by the City, and which lawful business or enterprise is predicated upon subsequent written agreement sufficiently detailed to ensure supervisory controls and measurable analysis that the public purpose is being met.

The filing of an application or request form is not intended to guarantee an award or granting of sales tax proceeds to an applicant. The City of Minot reserves the right to approve or reject applications and projects on a case by case basis, taking into consideration established policies, project criteria, and demand on City services and finances in relation to the potential benefits from the project. In the consideration of submitted applications, the City will address the specific and unique needs of the community as a whole and will review the submitted applications in terms of serving the best interests of the community. Approval or denial of one project is not intended to set precedence for approval or denial of another project. The City of Minot shall also consider whether funding of an identified project results in unfair advantage or constitutes unfair competition, if applicable, with similar competitors or other like businesses.

The City of Minot may also request additional information which is deemed necessary in the consideration and determination of a submitted application. Finally, applicants should note that all information submitted with respect to an application or request for sales tax proceeds in the construction, enhancement or improvement of community facilities, is subject to public disclosure, and that the City does not guarantee the confidentiality of the information submitted in the application process.

APPLICATION/REQUEST

Name of Organization/Facility:

Children's Museum of Minot, Inc. (dba Magic  
City Discovery Center) and Minot Park District

Contact Person/Spokesperson:

Mark Lyman, MCDC Board Member  
Ron Merritt, Park District Executive Dir.

Address:

Minot Park District, 420 3<sup>rd</sup> Ave. SW

Magic City Discovery Center, P.O. Box 751 Minot, ND 58702

Address:

Telephone No:

Telephone No.:

Lyman – 701-630-1443, Merritt – 857-4136

Type of Organization/Facility:

City/Public

Private Non-Profit

Another Governmental Entity

List of Applicant's Governing Board/Supervisor:

Children's Museum of Minot – Jessica Henderson, Board President; Karen Rasmusson, Board Vice-President; Wendy Keller, Treasurer; Jessica Ahmann, Secretary; Jessica Ackerman, Board Member; Rebecca Hogle, Board Member; Sally Jenkins, Board Member; Mark Lyman, Board Member; Laura Mihalick, Board Member; Perry Olson, Board Member; Tammy Hein-Sack, Board Member; Elizabeth Weeks, Board Member

Minot Park District – Nancy Beck, Board President; Cliff Hovda, Board Vice-President; Chuck Emery, Board Member; Steve Wharton, Board Member; John Drady, Board Member

Physical Location of Project:

Approximately 25 15<sup>th</sup> Avenue NE, just southwest of the Keith White Sertoma Sports Complex near the airport

Please describe this project and its benefits, and also explain how it relates to the community of Minot (For example, a description of the project or service; an outline of the project goals and intended results; a description of the economic impact of the project on the community; a projected time table for completion of the project; an explanation of how the City of Minot will benefit from the expenditure of sales tax proceeds for the project or service; and an explanation of how the outcome or success of the project will be evaluated or measured)

The Magic City Discovery Center (MCDC) grew out of a brain storming session sponsored by the Minot Area Community Foundation. Through those discussions a dream and then a plan arose to create the Magic City Discovery Center. For the past three years the museum partnered with the Dakota Territory Air Museum which provided space for educational exhibits, creativity and play.

Thousands of families visited the museum in its temporary space. It has been a resounding success, but it is now time for the Magic City Discovery Center to move forward and accept the challenge of building its own facility. The new permanent museum will provide a year-round destination for the entire Northwestern North Dakota region. It will improve the quality of life for those currently living here as well as be an attraction for families interested in moving to the region.

The board believes residents in the Minot region deserve a place that inspires children, supports families and builds communities. MCDC has done extensive research to ensure we build a sustainable children's museum that will be an invaluable resource for years to come. MCDC has hired national consultants to create a strategic plan. That plan estimates a direct and indirect annual economic impact to our region of \$2 million. We anticipate hiring four to six full-time employees and 15+ part-time employees. According to a popular non-profit calculator, a museum of the size we are proposing would generate annually \$200,000 in local and state tax revenue.

The Board plans on constructing a 20,000-square-foot building that is estimated to welcome 75,000 to 100,000 visitors per year, treating them to interactive STEAM (Science, Technology, Engineering, Art and Mathematics) based exhibits as well as outdoor exhibit space, educational classrooms and community multi-purpose space.

The board reached an agreement with the Minot Park District Board in late June that would allow MCDC to build on North Hill park district land. The site is visible from Broadway and provides a beautiful panoramic view of Minot. MCDC plans to open a hybrid (children's and science) museum that serves children from birth to age 14. Community feedback confirms the need for this incomparable educational experience and unique regional destination.

Our children and families in the Minot region deserve a place that inspires children, supports families and builds communities. Your support will give children and their families more than a winter place of engagement. It will give them an unparalleled view of the world and a deep appreciation of their hometown.

Potential timeline for the project:

Summer 2017 - Summer 2018 – Fundraising efforts

Summer/Fall 2018 – Groundbreaking

Up to two years of building construction and exhibit build-out

Winter 2019/Spring 2020 – Community Ribbon cutting

Mission – To engage children and families in the magic of life-long learning through discovery, creativity and play.

Vision – The Magic City Discovery Center will become a destination to bring young children, caregivers and families together, in an interactive environment that encourages creativity, play and education.

Specific amounts requested from the City of Minot and dates requested:

The Magic City Discovery Center is asking for \$2.5 million toward an approximate \$10 million capital campaign fundraising effort. Should this be the lead gift for the children's museum, the name would remain as is, to continue to honor the magical heritage that is a part of Minot's rich history. This funding would be needed in 2018 for excavation, foundation and other work associated with the new building.

Describe any alternative sources of funding, other than the City of Minot, which will be pursued with respect to this project (also please indicate whether those sources are presently confirmed or tentative funding sources).

Over the past three years the Magic City Discovery Center has raised in excess of \$100,000 to build, rent or develop exhibits that are part of the temporary museum (some of which will play a role in the new museum). In recent months, MCDC has secured a \$300,000+ donation from Ackerman-Estvold to do pro-bono engineering and architectural work associated with the new building. We have or are continuing to work with six consulting firms to assist with feasibility planning, community input, exhibit and educational analysis, exhibit fabrication, and building and location analysis. We anticipate being able to fundraise the dollars needed to appropriately complete the Magic City Discovery Center. We anticipate these funding sources will cover the remaining funds needed to build the 20,000 square-foot building, including 6 to 10 high-quality exhibit galleries, site improvements, outdoor landscaping, outdoor exhibit space, and other needs.

Please list any other information which the applicant believes should be considered by the City of Minot in the determination of this request.

We have attached additional materials that will be helpful in understanding the scope of the museum, the community's dedication to this unique effort, our partnership with the Minot Park District and the proposed future location of the new Magic City Discovery Center!

See attached documents:

A Case for a Children's Museum in Northwest North Dakota

Fundraising Request for Support Fact Sheet

North Hill building location concept

Magic Climber concept design

Other Exhibit concept designs

Letter of Intent to enter into an Enterprise Contractual Agreement with the Minot Park District

CERTIFICATION OF APPLICATION

The undersigned hereby certifies that both they and the entity listed in this application, and the specific request herein for the use of sales tax proceeds for community facilities, does not, and will not discriminate in its plans, programs, and activities on the basis of race, color, national origin, creed, religion, age, sex, handicap or any other basis which has been declared as discriminatory by federal or state cases or law.

Date: 6/30/17

Signature: Jessica Henderson

President

(Title/Position)





# MAGIC CITY DISCOVERY CENTER

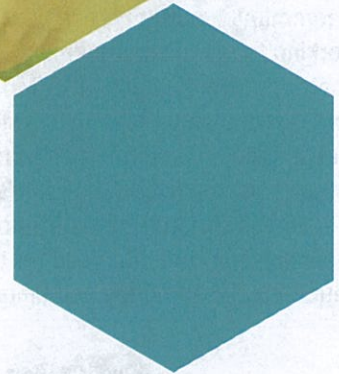
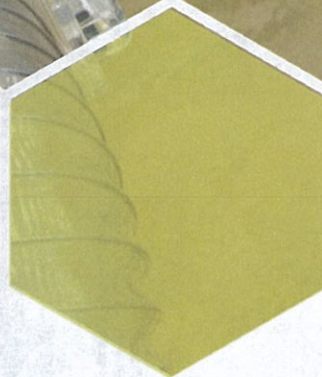
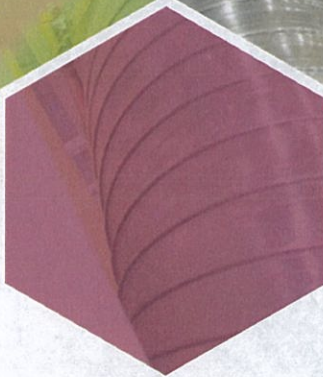
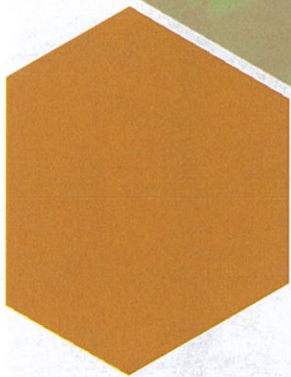

## OUR MISSION

*To engage children and families in the magic of life-long learning through discovery, creativity and play.*

## OUR VISION

The Magic City Children's Museum will become a destination to bring young children, caregivers and families together, in an interactive environment that encourages creativity, play and education.



## OUR HISTORY

The Magic City Discovery Center (MCDC) grew out of a brain storming session sponsored by the Minot Area Community Foundation. Through those discussions a dream and then a plan arose to create the Magic City Discovery Center. For the past three years the museum partnered with the Dakota Territory Air Museum which provided space for educational exhibits, creativity and play. Thousands of families visited the museum in its temporary space. It has been a resounding success, but it is now time for the Magic City Discovery Center to move forward and accept the challenge of building its own facility. The new permanent museum will provide a year-round destination for the entire Northwestern North Dakota region.



LETTER OF INTENT TO ENTER INTO AN ENTERPRISE CONTRACTUAL AGREEMENT  
BETWEEN MINOT PARK DISTRICT AND CHILDREN'S MUSEUM OF MINOT, INC.

WHEREAS, North Dakota Law authorizes a park district to enter into an enterprise contractual agreement with a private non-profit entity upon approval of the park district's governing body, for the undertaking of an enterprise between the two parties that is authorized by law.

WHEREAS, the Minot Park District, pursuant to N.D.C.C. Ch. 40-49 owns real Property in the City of Minot, located on North Hill, having the address approx. 25 15<sup>th</sup> Ave. NE which Property can be utilized for lawful purpose as authorized by statute and approved by the Minot Park District.

WHEREAS, the Children's Museum of Minot, Inc., a North Dakota nonprofit corporation, desires that a museum, designed to provide interactive exhibits and programs to stimulate learning experiences for children ("museum"), be constructed, and the Property on North Hill has been identified and designated as the possible location for the museum;

WHEREAS, the Minot Park District has powers, which include the sole and exclusive authority to maintain, govern, and improve its real Property, and to provide for the erection of structures on its Property which includes the North Hill Property; and

WHEREAS, the Parties hereto intend, in the manor authorized by North Dakota law, and upon terms satisfactory to the Minot Park District and the Children's Museum of Minot, Inc., to form and maintain a long-term relationship for the development, construction, and operation of the museum on the Property and wish to memorialize such intention through this Agreement.

NOW, THEREFORE, The Parties agree as follows:

1. This Agreement is made and entered into this 29<sup>th</sup> day of June, 2017, by and between the Minot Park District and the Children's Museum of Minot, Inc.
2. That the Children's Museum of Minot, Inc. intends on constructing a museum that will be designed to provide interactive exhibits and programs to stimulate learning experiences for children, and it is the Children's Museum of Minot, Inc.'s desire to construct this museum on the Property now owned by the Minot Park District.
3. That the Minot Park District has determined that the construction of a children's museum on its the Property will provide a benefit to the public consistent with the purposes and powers of the Minot Park District and that in support of this public benefit, prior to funding and construction of the children's museum, it hereby agrees to enter into a letter of intent to enter into an enterprise contractual agreement with the Minot Children's Museum, Inc., upon terms that would be mutually agreeable to both the Minot Park District and the Minot Children's Museum Inc., after passage of any required Minot Park District ordinances necessary to provide a basis for a lawful enterprise contractual agreement. It is both parties' intention that the resulting



enterprise contractual agreement would involve the Minot Park Districts leasing of land under a long-term lease agreement with the Children's Museum of Minot, Inc., upon terms agreeable to both parties, for a nominal amount, specifically \$1.00 a year for fifty (50) years with an option to renew for one consecutive fifty (50) year term.

4. That the Children's Museum of Minot, Inc. will have a period of five (5) years from the date of this agreement to obtain the necessary approvals from the Minot Park District and complete construction of the museum. If the museum is not completed by the Children's Museum of Minot, Inc. within this five (5) year period, the Parties will then determine if more time should be allowed to complete the museum. If no more time is allowed, the Park District will be entitled to unilaterally terminate this Agreement and the same will become null and void.
5. Once the plans for the financing and construction of the museum have been approved by the Minot Park District, and Minot Park District has passed any required ordinances that may be necessary to facilitate a lawful joint project, the Parties agree that they will enter into the final enterprise contractual agreement that will provide terms and conditions for the long-term leasing and care and maintenance of the real Property, the museum, parking lot, and related structures.
6. The Parties agree that the purpose and object of this Agreement is to provide a baseline letter of intent, as it relates generally to the enterprise contractual agreement between the parties relating to the construction of the museum, and the parties general understanding relating to the respective Parties' intent regarding the future operation of that museum.
7. This Agreement constitutes the entire Agreement between the parties.

IN WITNESS WHEREOF, the Parties have hereunto set their hands the day and year first above written.

MINOT PARK DISTRICT

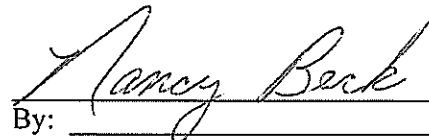
  
By: \_\_\_\_\_

ATTEST:

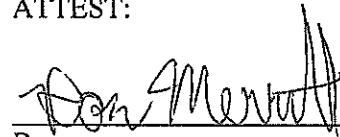
  
By: \_\_\_\_\_

CHILDREN'S MUSEUM OF MINOT, INC.

Jessica Henderson, President  
By: \_\_\_\_\_

ATTEST:  
[Signature]  
By: \_\_\_\_\_





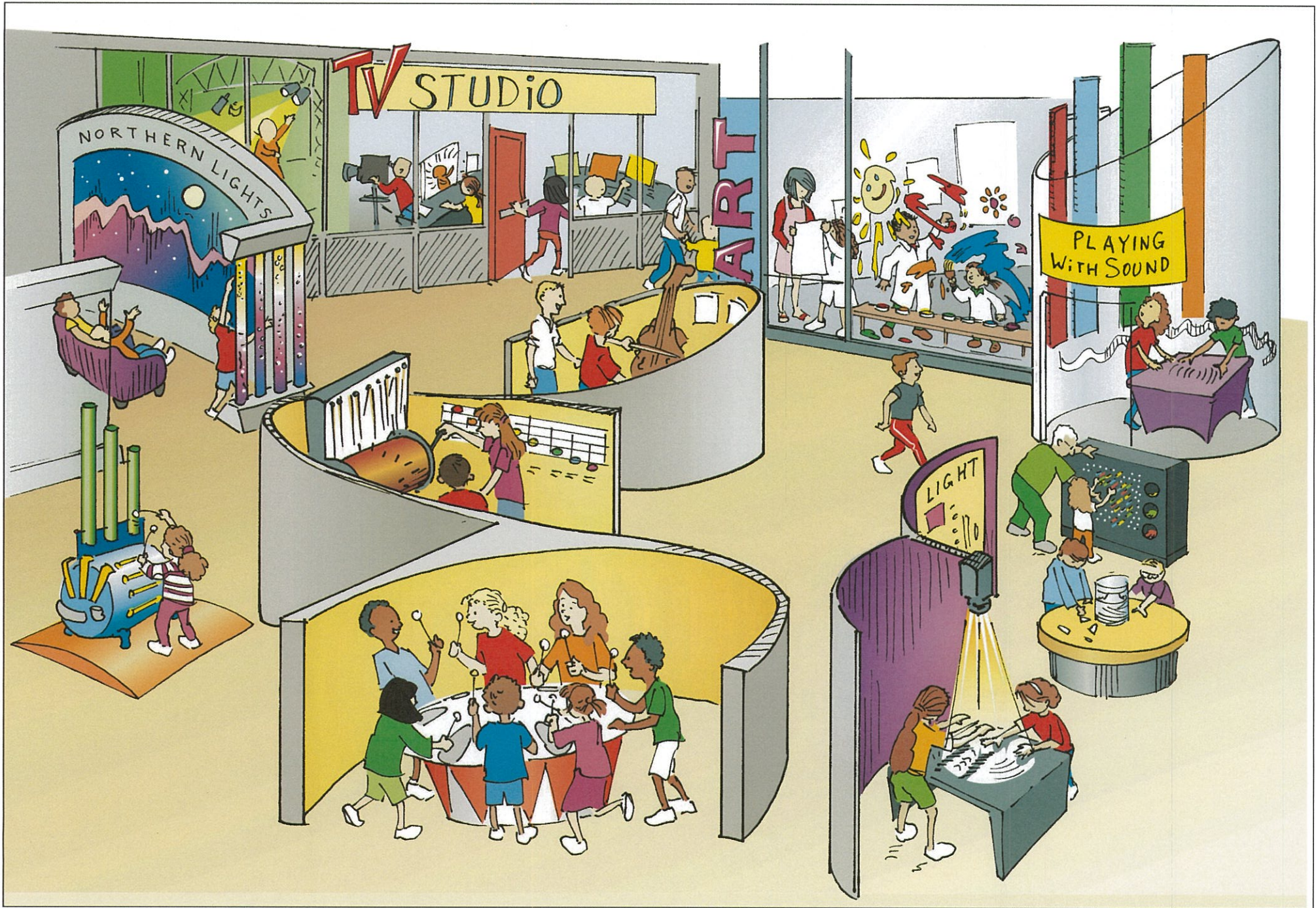



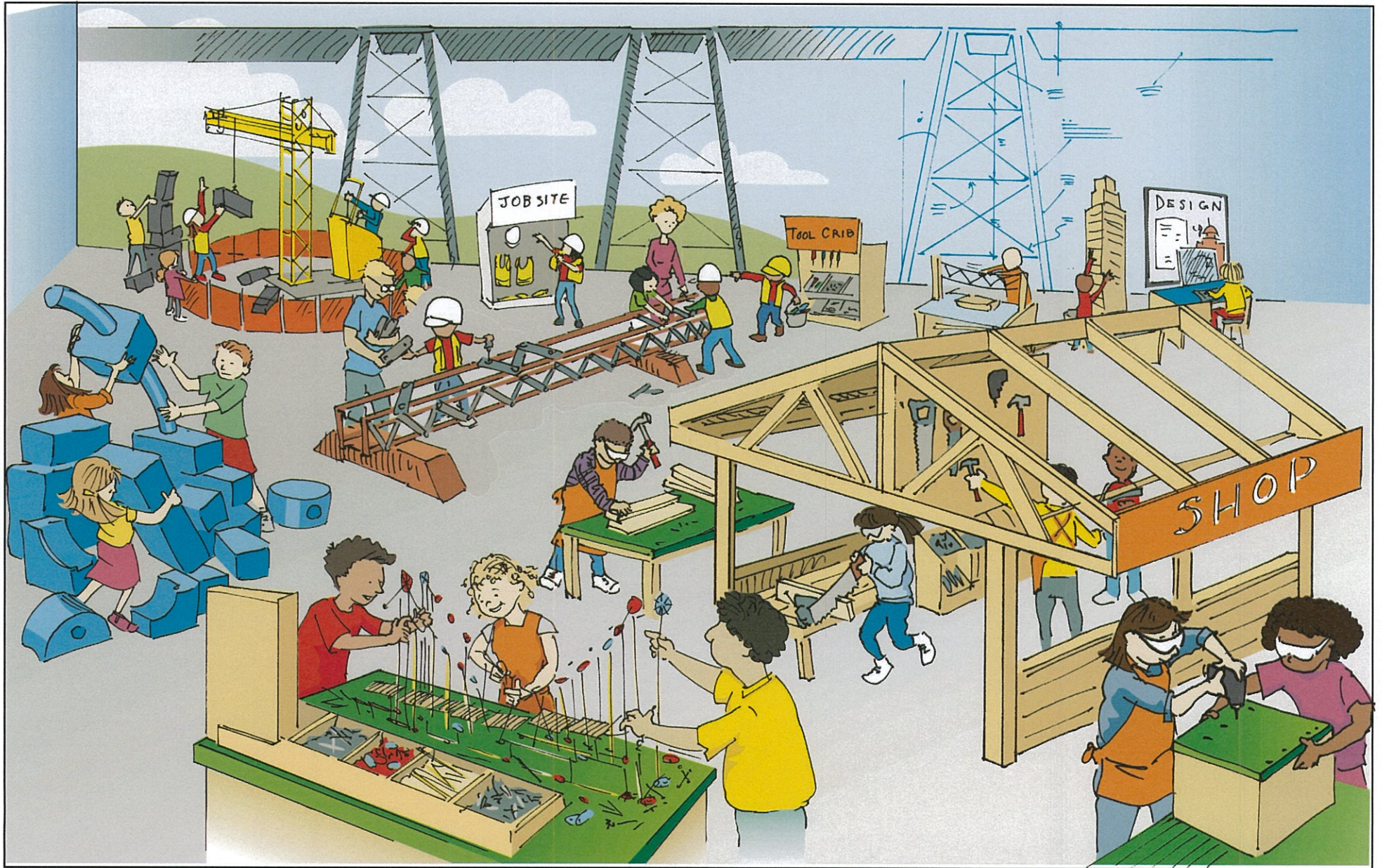



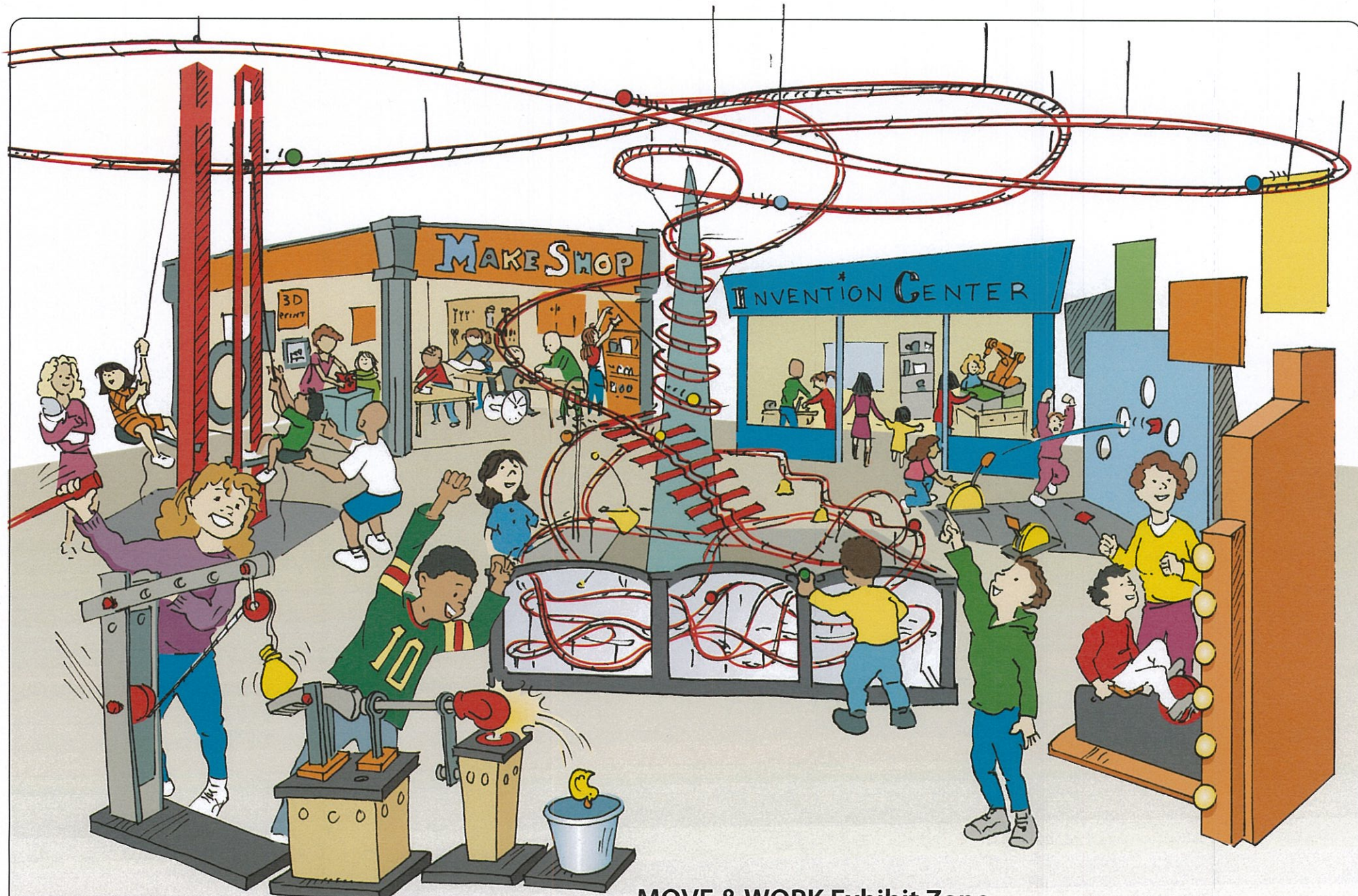

MindSplash/ KidZibits 6/2017

**MOVE & WORK Exhibit Zone**

Magic City Discovery Center





Image Source: Google Earth



**OPTION A**

**North Hill Location**

- Lot Size: ~ 76,000 sf (1.75 acres)
- Building: ~ 21,000 sf (3-story)
- Parking: ~ 62 spaces (on site)  
~ 24 spaces (off site)

**Pros**

- + Land could be donated by park district
- + Brand new facility
- + Visibility from Broadway
- + View of Minot

**Cons**

- Additional construction costs
- Sprawled parking
- Not located on arterial or collector road



# Minot Children's Museum Initiative History

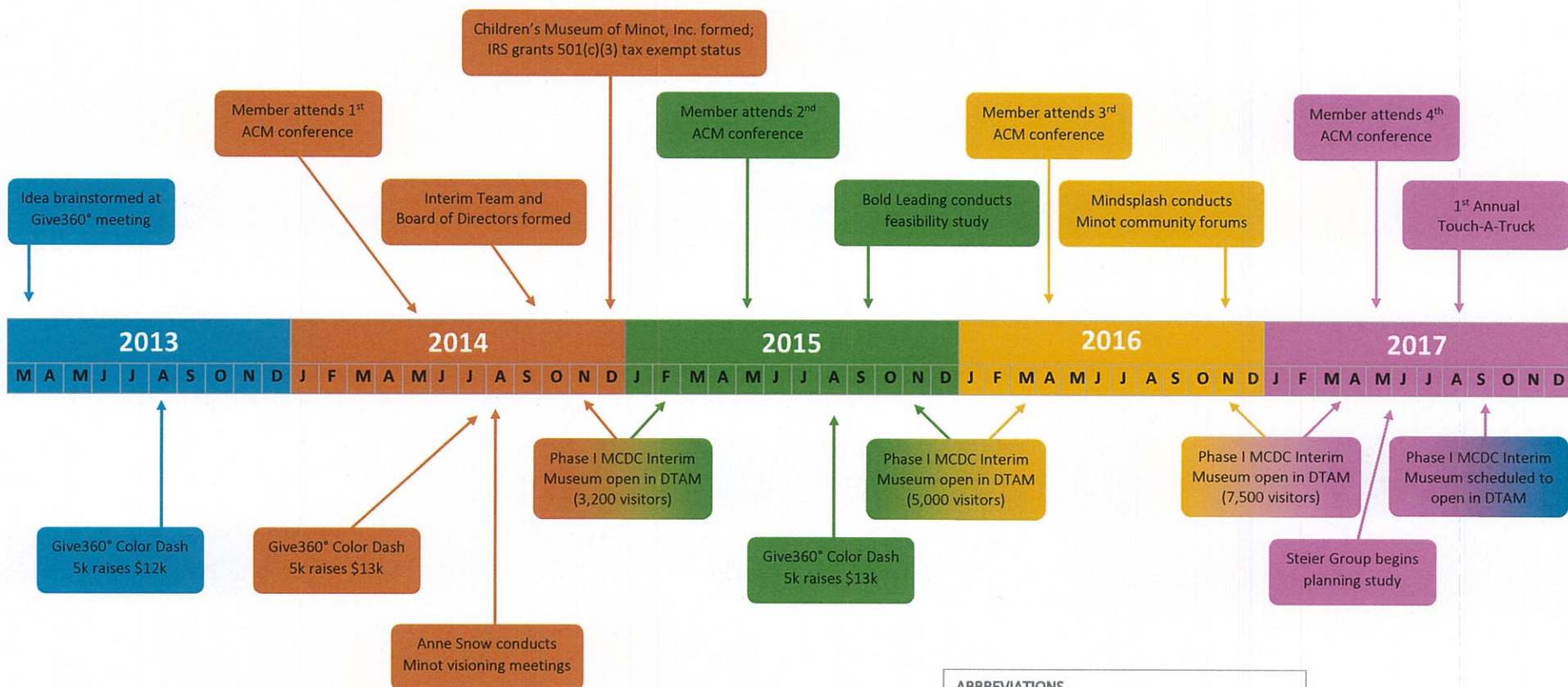

**ABBREVIATIONS**

MCDC: Magic City Discovery Center  
 ACM: Association of Children's Museums  
 DTAM: Dakota Territory Air Museum

COMMUNITY DEVELOPMENT COMMITTEE APPLICATION AND REQUEST FORM  
FOR USE OF SALES TAX PROCEEDS FOR

COMMUNITY FACILITIES

INTRODUCTION

Pursuant to Ordinance No. 4380 of the Minot Code of Ordinances, the City of Minot may make proceeds available from the city sales tax for purposes of upgrading, remodeling and constructing community facilities. These community facilities, for example, may be constituted by arenas, auditoriums, and facilities for conventions, tourist and sporting events. Community facilities must meet one of the following three categories in order to be eligible for possible funding: (1) community facilities owned directly by the City of Minot; (2) community facilities owned directly by another county, city, township, city park district, school district, or other political subdivision of the state of North Dakota, including any agency, board, or institution of the state of North Dakota, and for which entities an appropriate Joint Powers Agreement has been lawfully executed between the City of Minot and the applicable entity; and (3) community facilities of private non-profit entities with which the City of Minot has authority to engage in with respect to a lawful business or enterprise under North Dakota law meeting a public purpose and for which an independent and applicable implementing Ordinance has been passed by the City, and which lawful business or enterprise is predicated upon subsequent written agreement sufficiently detailed to ensure supervisory controls and measurable analysis that the public purpose is being met.

The filing of an application or request form is not intended to guarantee an award or granting of sales tax proceeds to an applicant. The City of Minot reserves the right to approve or reject applications and projects on a case by case basis, taking into consideration established policies, project criteria, and demand on City services and finances in relation to the potential benefits from the project. In the consideration of submitted applications, the City will address the specific and unique needs of the community as a whole and will review the submitted applications in terms of serving the best interests of the community. Approval or denial of one project is not intended to set precedence for approval or denial of another project. The City of Minot shall also consider whether funding of an identified project results in unfair advantage or constitutes unfair competition, if applicable, with similar competitors or other like businesses.

The City of Minot may also request additional information which is deemed necessary in the consideration and determination of a submitted application. Finally, applicants should note that all information submitted with respect to an application or request for sales tax proceeds in the construction, enhancement or improvement of community facilities, is subject to public disclosure, and that the City does not guarantee the confidentiality of the information submitted in the application process.

APPLICATION/REQUEST

Name of Organization/Facility:

City of Minot

Address:

515 2<sup>nd</sup> Ave SW

Minot, ND 58701

Telephone No:

701-857-4750

Contact Person/Spokesperson:

Dan Jonasson, Public Works Director

Address:

1025 31<sup>st</sup> St SE

Minot, ND 58701

Telephone No.:

701-857-4140

Type of Organization/Facility:

City/Public

Private Non-Profit

Another Governmental Entity

List of Applicant's Governing Board/Supervisor:

(Name/Address)

---

---

---

Physical Location of Project:

Carnegie Center 105 2<sup>nd</sup> Ave. SE Minot ND 58701

Please describe this project and its benefits, and also explain how it relates to the community of Minot (For example, a description of the project or service; an outline of the project goals and intended results; a description of the economic impact of the project on the community; a projected time table for completion of the project; an explanation of how the City of Minot will benefit from the expenditure of sales tax proceeds for the project or service; and an explanation of how the outcome or success of the project will be evaluated or measured)

The Carnegie Center was built in 1911 and is on the historical registry. The building has been used in the past for many different functions and activities. Music lessons and recitals, art displays, weddings and receptions and also some historical displays. It has had very good interior care and the HVAC has been upgraded, all in compliance of the historical registry compliance guidelines.

The building has had some settling in one corner of the structure and action to correct this situation before the building can no longer be repaired or saved. The north wall from the west corner is sunk to the point where a large crack has developed from the top to the bottom separating brick and mortar, window ledges and window sills and decorative concrete trim and caps. Many windows themselves, jambs and storm windows which are holding the "poured" glass panels also need resetting. Once the building has been stabilized, point tuck work on the brick would need to be done.

A project timeline would all determined after a structural engineer could determine the extent of the work needed to stabilize the structure and complete all the repairs needed to stay in compliance with the Historical Registry criteria.

The benefits to have this building preserved and available for all the different arts related events, and non-art as well, can only be measured by its historical place in Minot and the appreciation of those use and attend events there. The measure of this success will be the added events and use of the facility.

If available, please describe and attach diagrams, or schematic designs of the requested project

Specific amounts requested from the City of Minot and dates requested:

\$550,000 to include structural plans and design

---

---

Describe any alternative sources of funding, other than the City of Minot, which will be pursued with respect to this project (also please indicate whether those sources are presently confirmed or tentative funding sources).

---

---

---

---

---

Please list any other information which the applicant believes should be considered by the City of Minot in the determination of this request

   This facility is on the historical register and is required to be maintained and kept up in accordance with State Historical Requirements. It provides numerous ability's for public function such as wedding, art exhibits, etc.

---

---

---

---

---

---

---

---

CERTIFICATION OF APPLICATION

The undersigned hereby certifies that both they and the entity listed in this application, and the specific request herein for the use of sales tax proceeds for community facilities, does not, and will not discriminate in its plans, programs, and activities on the basis of race, color, national origin, creed, religion, age, sex, handicap or any other basis which has been declared as discriminatory by federal or state cases or law.

Date: 6/30/17

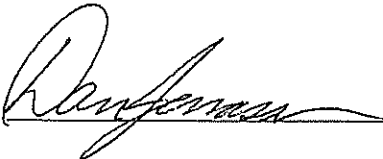
Signature: 

Director of Public Works  
(Title/Position)

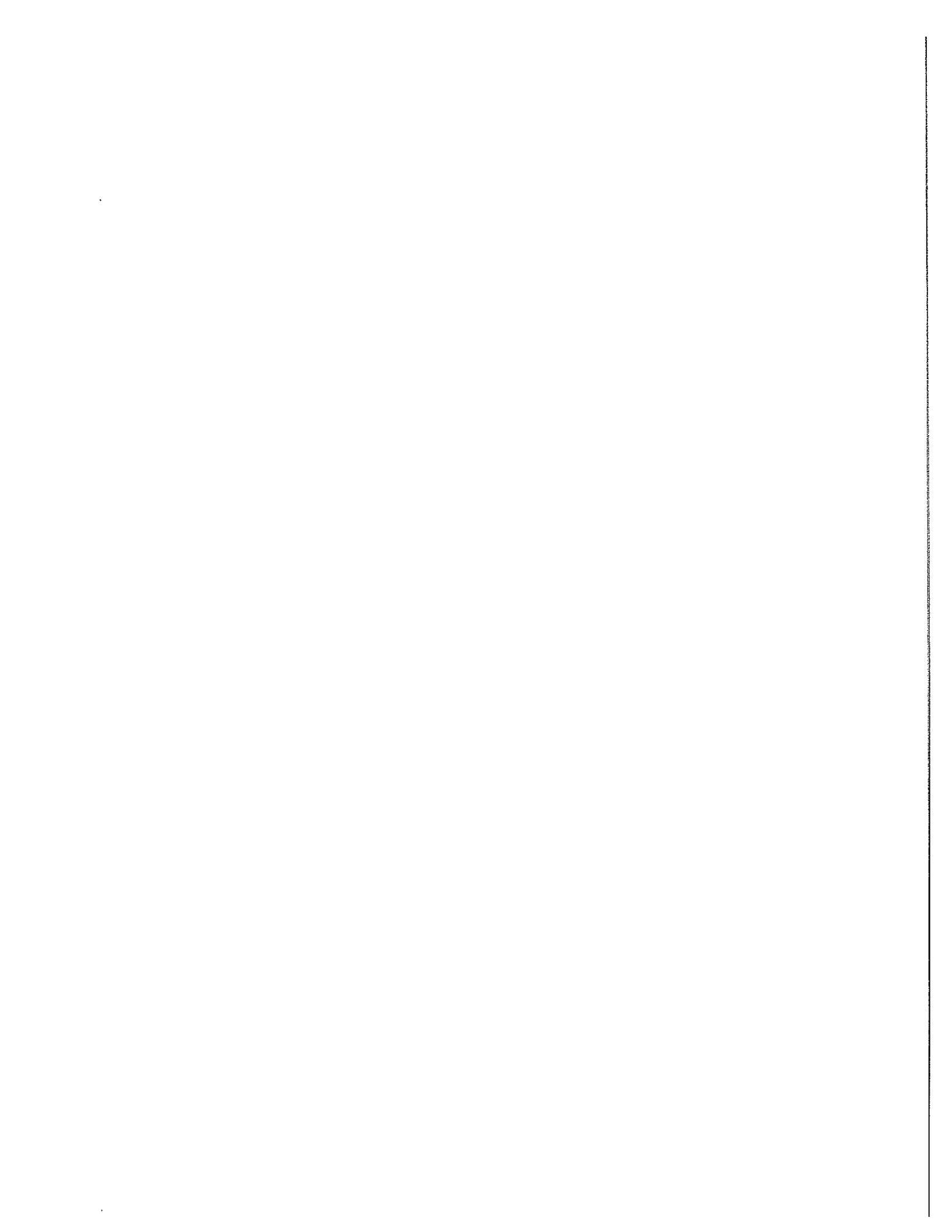



## COMMUNITY DEVELOPMENT COMMITTEE APPLICATION

### AND REQUEST FORM FOR USE OF SALES TAX PROCEEDS FOR COMMUNITY FACILITIES

#### INTRODUCTION

Pursuant to Ordinance No. 4380 of the Minot Code of Ordinances, the City of Minot may make proceeds available from the city sales tax for purposes of upgrading, remodeling and constructing community facilities. These community facilities, for example, may be constituted by arenas, auditoriums, and facilities for conventions, tourist and sporting events. Community facilities must meet one of the following three categories in order to be eligible for possible funding: (1) community facilities owned directly by the City of Minot; (2) community facilities owned directly by another county, city, township, city park district, school district, or other political subdivision of the state of North Dakota, including any agency, board, or institution of the state of North Dakota, and for which entities an appropriate Joint Powers Agreement has been lawfully executed between the City of Minot and the applicable entity; and (3) community facilities of private non-profit entities with which the City of Minot has authority to engage in with respect to a lawful business or enterprise under North Dakota law meeting a public purpose and for which an independent and applicable implementing Ordinance has been passed by the City, and which lawful business or enterprise is predicated upon subsequent written agreement sufficiently detailed to ensure supervisory controls and measurable analysis that the public purpose is being met.

The filing of an application or request form is not intended to guarantee an award or granting of sales tax proceeds to an applicant. The City of Minot reserves the right to approve or reject applications and projects on a case by case basis, taking into consideration established policies, project criteria, and demand on City services and finances in relation to the potential benefits from the project. In the consideration of submitted applications, the City will address the specific and unique needs of the community as a whole and will review the submitted applications in terms of serving the best interests of the community. Approval or denial of one project is not intended to set precedence for approval or denial of another project. The City of Minot shall also consider whether funding of an identified project results in unfair advantage or constitutes unfair competition, if applicable, with similar competitors or other like businesses.

The City of Minot may also request additional information which is deemed necessary in the consideration and determination of a submitted application. Finally, applicants should note that all information submitted with respect to an application or request for sales tax proceeds in the construction, enhancement or improvement of community facilities, is subject to public disclosure, and that the City does not guarantee the confidentiality of the information submitted in the application process.

---

**APPLICATION/REQUEST**

Name of Organization/Facility:	Contact Person/Spokesperson
<b>City of Minot – City Hall</b>	<b>Derek Hackett - PIO</b>
Address:	Name:
<b>515 2<sup>nd</sup> AVE SW</b>	<b>Derek Hackett</b>
	Address:
Telephone No:	<b>420 3<sup>rd</sup> Ave. SW</b>
<b>701-857-4750</b>	Telephone:
	<b>701-857-4727</b>

---

Type of Organization/Facility:

City/Public

Private Non-Profit

Another Governmental Entity

List of Applicant's Governing Board/Supervisor: **Minot City Council**

(Name/Address)

**See Attached**

---

Physical Location of Project: **515 2<sup>nd</sup> AVE SW**

---

Please describe this project and its benefits, and also explain how it relates to the community of Minot (For example, a description of the project or service; an outline of the project goals and intended results; a description of the economic impact of the project on the community; a projected time table for completion of the project; an explanation of how the City of Minot will benefit from the expenditure of sales tax proceeds for the project or service; and an explanation of how the outcome or success of the project will be evaluated or measured)

**The City of Minot is requesting Community Facility funding to make appropriate improvements to City Hall's Council Chambers to better serve people with disabilities in the community. Currently, Council Chambers is not completely in compliance with ADA standards. It does not aid any persons with hearing disabilities, and does not have appropriate access to the dais or podium for individuals with physical disabilities. Funds requested will be used to help alleviate any physical barriers people with disabilities may face if they wish to participate in community meetings held in Council Chambers.**

**Brief Scope of Improvements: (Expanded information attached)**

- A. A ramp to the dais will be constructed on the north wall and designed to blend with the existing interior design of the room.**
- B. A custom podium will be built to allow individuals who may be wheelchair bound the ability to speak into the microphone.**
- C. The podium will be equipped with a document projector for individuals who have brought supplemental documents they wish to share. This will allow everyone to see what is being discussed if copies were not supplied for the room.**

***Among the physical upgrades will be technical upgrades that will allow people to watch any and all meetings from their home via online streaming and cable broadcast.***

- D. Four cameras will be mounted to the ceiling. The cameras will allow for a better broadcast angle to each individual speaking at meetings. The current system does not allow for a proper shot of speakers at the podium. This will also allow Aldermen the capability of teleconferencing into meetings.
- E. Equipment upgrades to allow for hearing impairment technology. An Infrared transmitter will provide hearing assistance for individuals who may need it.
- F. Broadcast transmission equipment upgrades to allow a digital signal and program override from City Hall to Midco's cable feed for Channel 19, Public Access.
- G. Upgraded broadcast and presentation computer. To consistently run the broadcast software and the software used for the on-screen presentations an upgrade to the CPU is essential.

*See attached documents for project appendix*

---

If available, please describe and attach diagrams, or schematic designs of the requested project:

**Actual diagrams will be rendered if funds are approved by the Community Facilities Committee and the City of Minot City Council.**

---

Specific amounts requested from the City of Minot and dates requested:

**\$45,000 – A/V Upgrades and Installation**  
**\$15,000 – ADA Compliant Wheelchair Ramp**  
**\$ 3,500 – Midco Digital Broadcast Equipment**  
**\$ 3,000 – Contingency Overruns\***  
**\$ 2,000 – ADA Compliant Custom Podium**  
**\$ 1,500 - Dell Precision Work Station Mini Tower CPU**  
**\$70,000 - TOTAL**

---

Describe any alternative sources of funding, other than the City of Minot, which will be pursued with respect to this project (also please indicate whether those sources are presently confirmed or tentative funding sources)

N/A

---

Please list any other information which the applicant believes should be considered by the City of Minot in the determination of this request

**The need for appropriate accommodations for people with disabilities is apparent in our current Council Chambers. This project should address most, if not all, current needs. The addition of the wheelchair ramp eliminates an obvious physical barrier for individuals that may be deterred from running for Council based on physical impairments. The custom podium will hopefully eliminate some concern or hesitation for individuals with similar impairments from presenting or testifying at public meetings. The hearing assistance technology will allow those with hearing impairments to actively attend meetings and participate in discussions. The audio/visual upgrades proposed will bring meetings into the homes of any and every citizen that may not be able to attend meetings in person. The dual source of broadcasts ensures we are available to a more traditional household by means of cable broadcast rather than exclusively online streaming. Moreover, with a smaller Council the need for better connectivity is immense. The ability to conference call into meetings using this new technology will aid in a more digital, mobile, and connected government.**

---

CERTIFICATION OF APPLICATION

The undersigned hereby certifies that both they and the entity listed in this application, and the specific request herein for the use of sales tax proceeds for community facilities, does not, and will not discriminate in its plans, programs, and activities on the basis of race, color, national origin, creed, religion, age, sex, handicap or any other basis which has been declared as discriminatory by federal or state cases or law.

Date: \_\_\_\_\_

Signature: \_\_\_\_\_

(Title/Position) \_\_\_\_\_





# APPENDIX

## PROJECT DISCRIPTION AND SCOPE OF WORK

- A. **Wheel Chair Ramps** - Cutting back existing desk cabinet and counter to 48" from north wall, re-using and re-applying End panel at desk, wood framed ramp, full insulation inside of ramp, plywood deck, installing steel plate for glass rail anchoring, glass railing with wood top to match existing as best possible, wall rail and extended brackets on north wall, re-use existing carpet from below ramp to cover side of ramp, install carpet on ramp surface. Installation is including in cost and will be done by Craft Builders.

**Total Cost: \$15,000.00**

- B. **Custom Podium** – A custom built podium with slide outs on each side. Slide outs will, on one side, accommodate a document projector (see C.) the other will be handicap accessible. The custom podium will rotate 180 degrees to allow for conversion to face west. This may be used for press conferences, addressing audience members or general use presentations. Podium will be built by Property Maintenance.

**Total Cost: \$2,000.00**

- C. **Document Projector** – Often times a member of the community may bring a single sheet of paper with a diagram, proposal, or other images or verbiage to communicate. This may be difficult for the members of council or others in attendance to get the true and full value of the document and the effectiveness of the communication is suspect. A document projector will allow all to see one document on the large monitors in Chambers and will also be available for broadcast.

**Total Cost: \$1,500.00**



- D. **A/V Broadcast Upgrades** – Four mounted cameras will be located at the front, back, and both sides of the room to allow optimal angles for meeting broadcasts. A front mount camera will be fixed on the podium for a clear visual of the speaker. This camera will be able to pan, zoom, or tilt to adjust the shot. The current system will only shoot the back of the presenter’s head. The back-mount camera will be able to shoot the entire Council dais and/or the entire room. The two cameras located on each side of the room will cross shoot towards the dais. These will be primarily used to focus on the representatives speaking at the dais. Single shots will allow for better visibility for the speaker when engaging in discussion.

All cameras will be controlled in a control room behind the dais. This control room will be created as part of this project and will include a camera controller and a studio control board to manage the visuals of the broadcast as well as the display monitors in Council Chambers. Broadcast audio, document projection, display presentation, and cameras will be mixed and controlled by the program director in the control room. Equipment and installation will be provided by AVI Systems, who has the state contract for A/V equipment and installation.

Equipment Costs: \$31,000.00

Installation Costs: \$12,000.00

**Total Cost: \$42,885.94**

- E. **Hearing Assistance Equipment** – For those with hearing impairments, attending meetings where presenters either have their backs to the crowd or are a considerable distance away from the attendees can be troublesome. This project will install infrared transmitters that tap into the existing audio system for those that may need that accommodation. The transmitter can cover up to 30,000 square feet. This will be included in the A/V installation by AVI systems.

**Total Cost: \$2,114.06\***

*\*Will be added to equipment and installation of A/V Upgrades*

- F. **Broadcast Equipment Upgrade** – In addition to the camera and broadcast equipment outlined in D, the need for additional equipment and infrastructure is necessary to connect Council Chambers to Midco’s network. Infrastructure costs have been negotiated and will be absorbed by Midco. Equipment costs will fall

onto the City. This will be installed by Midco.

**Total Cost (to City): \$3,500.00**

- G. Broadcast CPU** – Running the operating system for broadcast along with multiple programs for the presentation will take a considerable amount of RAM and storage. The current CPU in Council Chambers is not equipped to handle the load. IT was consulted as to which machine may be the most appropriate for the workload. A Dell Precision Workstation T3620 Mini Tower was the recommendation. This machine will have a 512GB solid state drive and 32 GB of RAM to allow for multiple programs to run efficiently. IT will install and prepare this CPU.

**Total Cost: \$1,500.00**

- **\*Contingency Overruns** - Due to the nature of work needed there may be unforeseen issues that must be addressed during installation. This additional amount should be more than enough to cover any unexpected overages. Some issues may be need for power source, added cable length, need for upgraded equipment, etc.

**Total Cost: \$3,000.00**

COMMUNITY DEVELOPMENT COMMITTEE APPLICATION AND REQUEST FORM  
FOR USE OF SALES TAX PROCEEDS FOR

COMMUNITY FACILITIES

INTRODUCTION

Pursuant to Ordinance No. 4380 of the Minot Code of Ordinances, the City of Minot may make proceeds available from the city sales tax for purposes of upgrading, remodeling and constructing community facilities. These community facilities, for example, may be constituted by arenas, auditoriums, and facilities for conventions, tourist and sporting events. Community facilities must meet one of the following three categories in order to be eligible for possible funding: (1) community facilities owned directly by the City of Minot; (2) community facilities owned directly by another county, city, township, city park district, school district, or other political subdivision of the state of North Dakota, including any agency, board, or institution of the state of North Dakota, and for which entities an appropriate Joint Powers Agreement has been lawfully executed between the City of Minot and the applicable entity; and (3) community facilities of private non-profit entities with which the City of Minot has authority to engage in with respect to a lawful business or enterprise under North Dakota law meeting a public purpose and for which an independent and applicable implementing Ordinance has been passed by the City, and which lawful business or enterprise is predicated upon subsequent written agreement sufficiently detailed to ensure supervisory controls and measurable analysis that the public purpose is being met.

The filing of an application or request form is not intended to guarantee an award or granting of sales tax proceeds to an applicant. The City of Minot reserves the right to approve or reject applications and projects on a case by case basis, taking into consideration established policies, project criteria, and demand on City services and finances in relation to the potential benefits from the project. In the consideration of submitted applications, the City will address the specific and unique needs of the community as a whole and will review the submitted applications in terms of serving the best interests of the community. Approval or denial of one project is not intended to set precedence for approval or denial of another project. The City of Minot shall also consider whether funding of an identified project results in unfair advantage or constitutes unfair competition, if applicable, with similar competitors or other like businesses.

The City of Minot may also request additional information which is deemed necessary in the consideration and determination of a submitted application. Finally, applicants should note that all information submitted with respect to an application or request for sales tax proceeds in the construction, enhancement or improvement of community facilities, is subject to public disclosure, and that the City does not guarantee the confidentiality of the information submitted in the application process.



APPLICATION/REQUEST

Name of Organization/Facility:

City of Minot – Recycling Transfer Facility

Address:

PO Box 5006

Minot, ND 58702

Telephone No:

701-857-4140

Contact Person/Spokesperson:

Jason Sorenson

Address:

\_\_\_\_\_

\_\_\_\_\_

Telephone No.:

\_\_\_\_\_

Type of Organization/Facility:

City/Public

Private Non-Profit

Another Governmental Entity

List of Applicant's Governing Board/Supervisor:

(Name/Address)

Dan Jonasson

\_\_\_\_\_

\_\_\_\_\_

Physical Location of Project:

Minot Municipal Landfill



Please describe this project and its benefits, and also explain how it relates to the community of Minot (For example, a description of the project or service; an outline of the project goals and intended results; a description of the economic impact of the project on the community; a projected time table for completion of the project; an explanation of how the City of Minot will benefit from the expenditure of sales tax proceeds for the project or service; and an explanation of how the outcome or success of the project will be evaluated or measured)

Due to a high volume of requests from citizens of Minot, a presentation was given to the Minot City Council outlining what a recycling program could look like and what steps the City would need to take to get a recycling program off the ground. Following this presentation a recycling ad hoc committee was formed to work through the issues and hurdles of a recycling program. After the committee researched and studied recycling for about 4 months a recommendation was made to the City Council that a recycling program would be a benefit to the City of Minot and moves should be made to implement one.

As we are currently rolling out automated trash collection, which was the first step toward implementing recycling, we are looking at the next phase of the ad committee recommendation to build a recycling transfer facility. Since the main goal of any recycling program is to divert as much recyclable material as possible from the landfill, single stream recycling was the chosen method as it is proven to have the highest diversion rates. The drawback to single stream is that those materials need to be again separated into their individual commodities for marketing. Minot is located about 500 miles from the nearest materials recovery facility or MRF, thus the need for a transfer facility.

The addition of a transfer facility will not only benefit the City of Minot, but it will benefit the region. Minot Municipal Landfill is a regional landfill that accepts waste from 7 different counties. Annually, nearly 80,000 tons of municipal solid waste is disposed of in the Minot Landfill. Over half of this volume is coming in from surrounding communities in the region. While a well-run recycling program in Minot could divert thousands of tons of waste from the landfill, the City can only affect what is generated within our community. By building a transfer facility, recycling is made available to the region and many communities have already expressed interest in implementing their own recycling program including the Minot Air Force Base.

Pending a funding source, a transfer facility could be designed in 2018 with construction to follow and a probable completion date of early 2019. While the transfer facility is being constructed, implementation plans for a recycling program would be drafted so recycling could begin soon after the facility is complete. The economic and environmental benefits would immediately be realized once a recycling program starts as materials would start to be diverted from the Minot Landfill to a MRF in Minneapolis so new markets can utilize these products.

---

---

---

---

If available, please describe and attach diagrams, or schematic designs of the requested project





Specific amounts requested from the City of Minot and dates requested:

Design and Cnstruction is estimated to cost approximately \$2.5 million. In order to get the facility completed by early 2019, funding is requested for October of 2017.

Describe any alternative sources of funding, other than the City of Minot, which will be pursued with respect to this project (also please indicate whether those sources are presently confirmed or tentative funding sources).

Without community facilities sales tax dollars, design and construction of a transfer facility will be incorporated into the 2018 Landfill budget with utility bonds as the funding source.

---

---

---

---

Please list any other information which the applicant believes should be considered by the City of Minot in the determination of this request

---

---

---

---

---

---

---

---

---

---



## CERTIFICATION OF APPLICATION

The undersigned hereby certifies that both they and the entity listed in this application, and the specific request herein for the use of sales tax proceeds for community facilities, does not, and will not discriminate in its plans, programs, and activities on the basis of race, color, national origin, creed, religion, age, sex, handicap or any other basis which has been declared as discriminatory by federal or state cases or law.

Date: \_\_\_\_\_

Signature: \_\_\_\_\_

\_\_\_\_\_  
(Title/Position)



**COMMUNITY DEVELOPMENT COMMITTEE APPLICATION  
AND REQUEST FORM FOR USE OF SALES TAX PROCEEDS FOR  
COMMUNITY FACILITIES**

**INTRODUCTION**

Pursuant to Ordinance No. 4380 of the Minot Code of Ordinances, the City of Minot may make proceeds available from the city sales tax for purposes of upgrading, remodeling and constructing community facilities. These community facilities, for example, may be constituted by arenas, auditoriums, and facilities for conventions, tourist and sporting events. Community facilities must meet one of the following three categories in order to be eligible for possible funding: (1) community facilities owned directly by the City of Minot; (2) community facilities owned directly by another county, city, township, city park district, school district, or other political subdivision of the state of North Dakota, including any agency, board, or institution of the state of North Dakota, and for which entities an appropriate Joint Powers Agreement has been lawfully executed between the City of Minot and the applicable entity; and (3) community facilities of private non-profit entities with which the City of Minot has authority to engage in with respect to a lawful business or enterprise under North Dakota law meeting a public purpose and for which an independent and applicable implementing Ordinance has been passed by the City, and which lawful business or enterprise is predicated upon subsequent written agreement sufficiently detailed to ensure supervisory controls and measurable analysis that the public purpose is being met.

The filing of an application or request form is not intended to guarantee an award or granting of sales tax proceeds to an applicant. The City of Minot reserves the right to approve or reject applications and projects on a case by case basis, taking into consideration established policies, project criteria, and demand on City services and finances in relation to the potential benefits from the project. In the consideration of submitted applications, the City will address the specific and unique needs of the community as a whole and will review the submitted applications in terms of serving the best interests of the community. Approval or denial of one project is not intended to set precedence for approval or denial of another project. The City of Minot shall also consider whether funding of an identified project results in unfair advantage or constitutes unfair competition, if applicable, with similar competitors or other like businesses.

The City of Minot may also request additional information which is deemed necessary in the consideration and determination of a submitted application. Finally, applicants should note that all information submitted with respect to an application or request for sales tax proceeds in the construction, enhancement or improvement of community facilities, is subject to public disclosure, and that the City does not guarantee the confidentiality of the information submitted in the application process.

---

APPLICATION/REQUEST

Name of Organization/Facility:  
**City of Minot – Municipal Auditorium**

Contact Person/Spokesperson:  
**Scott Collins - Director**

Address:  
**420 3<sup>rd</sup> Ave. SW**

Name:  
**Scott Collins**

Telephone No:  
**701-857-4730**

Address:  
**420 3<sup>rd</sup> Ave. SW**

Telephone No:  
**701-857-4730**

---

Type of Organization/Facility:

City/Public

Private Non-Profit

Another Governmental Entity

List of Applicant's Governing Board/Supervisor: **Minot Recreation Commission –  
Minot City Council**

(Name/Address)  
**See Attached**

---

Physical Location of Project: **420 3<sup>rd</sup> Ave. SW, Minot, ND 58701**

---

Please describe this project and its benefits, and also explain how it relates to the community of Minot (For example, a description of the project or service; an outline of the project goals and intended results; a description of the economic impact of the project on the community; a projected time table for completion of the project; an explanation of how the City of Minot will benefit from the expenditure of sales tax proceeds for the project or service; and an explanation of how the outcome or success of the project will be evaluated or measured)

**The Minot Recreation Commission is requesting funds to replace the Auditorium Flooring in the Main Arena of the Municipal Auditorium, the existing tartan floor was installed in 1992. The Auditorium floor would be replaced with a similar type of tartan floor which would still allow for multiple events and athletic activities.**

The floor is 25 years old and has outlived the life expectancy. The main arena floor is used for recreation basketball and volleyball, roller derby, auctions, concerts, weddings, dances, multiple community events and meetings, along with many years of the Shrine Circus. The Recreation/Auditorium Director would also do preliminary concrete testing to determine the “Best” possible floor system for the Auditorium. The Engineers estimate for this project is \$235,000.

The Recreation/Auditorium is also requesting Community Funds to replace the remaining 543 light fixtures that have the T12 Bulb system. The lights were installed in 1992 during the last remodel and the T12 bulbs are no longer manufactured. The Auditorium has replaced many of the T12 lights during other remodeling projects and this phase would finish the remaining areas of the building that were not updated. Engineers estimate for this project for 543 Florescant Lights to be replaced with High Efficient LED Lights is \$150,000.

---

If available, please describe and attach diagrams, or schematic designs of the requested project:

**Actual plans and Specifications will be drawn up if funds are approved by the Community Facilities Committee and the Minot City Council.**

---

Specific amounts requested from the City of Minot and dates requested:

**\$175,000 – Auditorium Arena Flooring**  
**\$ 50,000 – Auditorium Arena Removal**  
**\$ 10,000 – Engineering Costs**  
**\$235,000**

**\$150,000 – Auditorium Complex LED Light Fixture Replacement (T12 Fixtures)**  
**\$ 7,500 – Engineering Costs**  
**\$157,500**

**\$392,500 - Total Amount Requested for Auditorium Projects**

---

Describe any alternative sources of funding, other than the City of Minot, which will be pursued with respect to this project (also please indicate whether those sources are presently confirmed or tentative funding sources)

N/A

---

Please list any other information which the applicant believes should be considered by the City of Minot in the determination of this request

**The City of Minot and the Minot Recreation Commission has always looked at keeping costs down and I believe we have done that when it comes to building updates through the years. The Auditorium Arena flooring is 25 years old and replacing the flooring is much needed. The floor has no aesthetic look to it any longer and has numerous gauges from heavy use over the past 25 years.**

**The Auditorium Complex Light fixtures that need to be replaced are no longer manufactured. Bulbs are still available, but when supplies run out, we will no longer have the ability to purchase T12 Bulbs. The Auditorium has replaced all light fixtures included in any of the previous construction/remodel projects and need to complete the replacement of the remaining 25 year old light fixtures.**

**The Auditorium Complex holds many community, social and sporting events throughout the year and countless meetings and community gatherings.**

---

#### CERTIFICATION OF APPLICATION

The undersigned hereby certifies that both they and the entity listed in this application, and the specific request herein for the use of sales tax proceeds for community facilities, does not, and will not discriminate in its plans, programs, and activities on the basis of race, color, national origin, creed, religion, age, sex, handicap or any other basis which has been declared as discriminatory by federal or state cases or law.

Date: \_\_\_\_\_

Signature: \_\_\_\_\_

(Title/Position) \_\_\_\_\_



## Community Facilities Fund Application

**Name of Organization:** Minot State University

**Supporting Organizations:** Minot Area Chamber of Commerce, Visit Minot, Minot Innkeepers Association, Minot Public Schools Activities Department, Bishop Ryan Catholic School

**Facility:** Minot State University Dome

**Phone Number:** 701-858-3300

**Contact Person/Spokesperson:** Steve Shirley, MSU president

**Supporting Organization Contacts:** John MacMartin (Minot Chamber), Phyllis Burckhard (Visit Minot), Amanda Shappell (Minot Innkeepers), Mitch Lunde (MPS Activities), Steve Lipp (BRCS)

**Address:** 500 University Ave West, Minot, ND

**Phone Number:** 701-858-3300

**Type of Organization/Facility:** Public University; Government Entity

**List of Applicant's Governing Board/Supervisor:** North Dakota University System and North Dakota State Board of Higher Education

**Physical Location of Project:** The MSU Dome is located on the Minot State University campus

### Benefits and Description of Project:

This request is for the replacement of seating in the MSU Dome on the Minot State University campus. The bleachers and chairs currently in the Dome represent the original seating installed in 1981 when the Dome was constructed. The purchase of new spectator seating will allow for safe and comfortable seating for those attending the many events held annually at the MSU Dome. Updated seating will also help attract additional events and new visitors to the facility and to the Minot community. The Dome provides seating for 10,000 spectators and is one of the largest arenas in the Upper Midwest.

This request will help ensure the Minot community has a facility that provides an outstanding environment for the thousands who come to the Dome every year. Seating is vital to the comfort and overall experience for spectators, thus setting the stage for Minot to realize a positive economic impact through continued and increased attendance at Dome events. Events at the MSU Dome lead directly to an increase in lodging tax revenue, retail sales, and food/beverage sales in Minot. In addition to this increased economic impact is a quality of life enhancement for area citizens due to the many events held annually at the Dome. Other similar facilities in North Dakota are constantly upgrading their amenities, and we must do so to remain competitive and continue attracting major events to our community.

Among others, the following activities have taken place in the Dome:

- North Dakota State Class A and B Basketball Tournaments (Boys and Girls)
- North Dakota Region 6 Boys Basketball Tournament

- North Dakota High School Wrestling Tournaments
- North Dakota State Class B Volleyball Tournament
- Northwest Conference Indoor Track Meet
- Central North Dakota Conference Indoor Track Meet
- Dakota Thunder Volleyball Tournament
- North Dakota State Indoor Soccer Tournament
- North Dakota State Amateur Basketball Tournament
- Minot High School Graduation
- Minot State University Graduation
- Our Redeemers Christian School Class B Day (held twice a year)
- Hoopster Classic - Basketball Jamboree
- Marketplace for Kids
- St. Alexius Childrens Olympics
- North Dakota Special Olympics
- March of Dimes Walk-a-Thon
- MSU Pow Wow
- Pursuit Church Group
- Dreamcatchers Baseball Community Engagement
- MSU Men's and Women's basketball games
- MSU Volleyball games
- MSU Wrestling matches
- Track and field practices and meets
- MSU Futurepalooza (college fair)
- Women's Basketball 5 on 5 Tournament
- Women's Basketball Sunday Night League
- Men's Basketball Sunday Night League
- Women's Basketball Spring 3 on 3 Tournament
- Beaver Booster Boys 5 on 5 Tournament
- Minot State Athletic Camps
- Minot Youth for Christ Banquet

Letters of support from several community organizations are also attached.

The City of Minot will directly benefit from this project. Visitors, fans, and traveling teams/participants buy gas, shop in our stores, dine in our restaurants, and stay in our hotels. Thanks to the MSU Dome and its wide variety of large events, there is enormous economic activity that benefits the greater Minot community.

**If available, please describe and attach diagrams or schematic designs of the requested project:**

See attached photos and quotes.

**Specific amounts requested from the City of Minot and dates requested:**

The total cost of new seating and installation is \$2 million. MSU is requesting \$2 million from the Community Facilities Fund. If funds are realized through this request, construction could begin in spring 2018 with substantial completion by August 2018.

**Describe any alternative sources of funding other than the City of Minot.**

Alternative sources of funding for this project are limited. MSU cannot seek state funding to enhance athletic facilities, so external sources of funding (such as the Community Facilities Fund) is a critical option of support for the Dome seating renovation. MSU would continue to be responsible for all annual operating costs associated with the Dome.

**Please list any other information which the applicant believes should be considered by the City of Minot in the determination of this request.**

According to the most recent data (fiscal year 2015) compiled by the North Dakota University System, Minot State University has an annual economic impact of nearly \$200 million on the Minot region. Additionally, other estimates have shown the impact of a single Class B Boys Basketball state tournament over just a few days to be in the millions of dollars for Minot. Clearly, MSU and the MSU Dome create a major positive economic impact in Minot.

Minot State University enjoys a great relationship with the City of Minot and is deeply thankful to the City for other Community Facilities Fund investments that have been made. Making the investment associated with this request will help ensure the MSU Dome remains a relevant facility, thereby continuing to attract regional and statewide events to Minot. MSU has made significant upgrades to the MSU Dome, including the recent installation of one of the largest indoor video screens in the upper Midwest. New seating is a critical need for this nearly 40-year old facility. The current seating, original and nearly four decades old, has become a major detriment for the Dome. During the past year, over 100,000 people attended events in the MSU Dome. These seating upgrades will help ensure the MSU Dome continues to be competitive with other similar facilities throughout North Dakota as we work to attract future events to our community.



1020 20th Avenue SW  
PO Box 940  
Minot, North Dakota 58702-0940

Telephone: 701.852.6000  
Facsimile: 701.838.2488  
e-mail: [chamber@minotchamber.org](mailto:chamber@minotchamber.org)  
Website: [www.minotchamber.org](http://www.minotchamber.org)

Community Facilities Committee:

The MSU Dome has been in our community for over 30 years. Back in the day, the legislature challenged the Minot community to raise a specific amount of money in order to receive an appropriation from the legislature, and I believe the community only had three days to secure the money and/or pledges. Minot rallied, raised the dollars locally and received the needed funding from the state.

The Chamber was part of that effort to secure the funding for the Dome, so it is fitting that we now have the opportunity to lend our support to the request for funding to help replace the 30-plus year old seating in the Dome. The Dome brings people to Minot who in turn eat, sleep and support our merchants. As such, the Chamber supports this project.

Respectfully,

A handwritten signature in cursive script that reads 'L. John MacMartin'.

L. John MacMartin, CCE  
President  
Minot Area Chamber of Commerce  
(o) 701-857-8203  
(c) 701-833-7603



1020 South Broadway  
PO Box 2066  
Minot, ND 58701  
T 800.264.2626 701.857.8206

June 26, 2017

Community Development Committee  
City of Minot  
515 2<sup>nd</sup> Avenue SW  
Minot, ND 58701

Dear Community Development Committee:

Minot is fortunate to have a venue like the Minot State University Dome to host incoming events and tournaments in our city. Visit Minot understands the importance of the Dome, and what it does for our community which is why we are writing in support of Minot State University and their request for funding to update the Dome's stadium chairs. The chairs have been in the Dome since its opening in 1981, and have seen many tournaments, Pow Wow's, graduations, and events.

The Dome is an important building for large scale tournaments, events and activities which bring additional business to our local economy. Having a site of this caliber and magnitude provides the City of Minot, and Visit Minot an opportunity to continue to host large events which has a positive economic impact on our city, its hotels, and business.

After many years of use, the current stadium chairs have been used thousands of times and are in need of being replaced. In short, Minot State University and the City of Minot would benefit from having updated stadium chairs in the Dome and Visit Minot supports their goals and efforts in continuing to keep this venue competitive with others in the region.

Sincerely,  
Visit Minot Convention & Visitors Bureau

A handwritten signature in black ink that reads "Phyllis Burckhard".

Phyllis Burckhard  
Executive Director

A handwritten signature in black ink that reads "Rianne Kuhn".

Rianne Kuhn  
Director of Marketing and Communications

June 27, 2017

To Whom it May Concern,

I am writing in regards to the request for funding applied for by Minot State University for improvements to the seating at the MSU Dome. On behalf of the Minot Innkeepers Association, we are submitting a letter of support for the funding, as we feel new seating will greatly enhance the value this venue adds to the city.

MSU's goal of this project is to provide the greater Minot community with a facility that provides an outstanding spectator and participant venue. The seating aspect is vital to the comfort and overall experience for the visiting fan, thus setting the stage for Minot to realize an economic impact through increased attendance. This leads directly to an increase lodging tax revenue, retail sales and food/beverage sales. In addition to this increased economic impact is a quality of life component for the citizens of Minot and the surrounding area. These are all key components to facilitate an outstanding venue for the city of Minot to remain competitive in drawing and keeping events in the future.

Sincerely,

**Amanda Shappell**

President, Minot Innkeepers Association  
General Manager, Hampton Inn and Suites Minot Airport  
1400 North Broadway  
Minot, ND 58703  
Phone: 701-838-1400  
Fax: 701-838-1401  
[amanda.shappell@hilton.com](mailto:amanda.shappell@hilton.com)

**Tutt Construction**  
1355 Cloverleaf Pl  
Billings, MT 59106

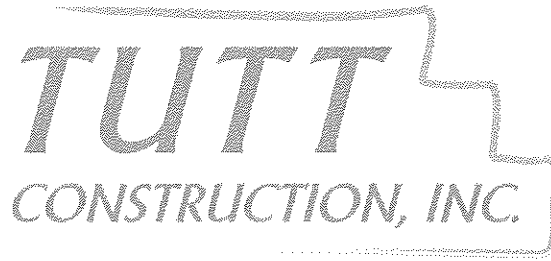

**Quote #21752**  
Phone 406-656-4685

*Your Spectator Seating Professionals*

**Minot State University**  
500 University Ave W.  
Minot, North Dakota 58707

Service / Product	Description	Total
Upper Level Seating	Replace Upper level seating with the same size and type as the existing seating layout.	\$450,000.00
Main Floor Seating	Replace Main Floor seating with the same size and type as the existing seating layout.	\$1,550,000.00

This quote is valid for the next 30 days, after which values may be subject to change.

**Total** **\$2,000,000.00**





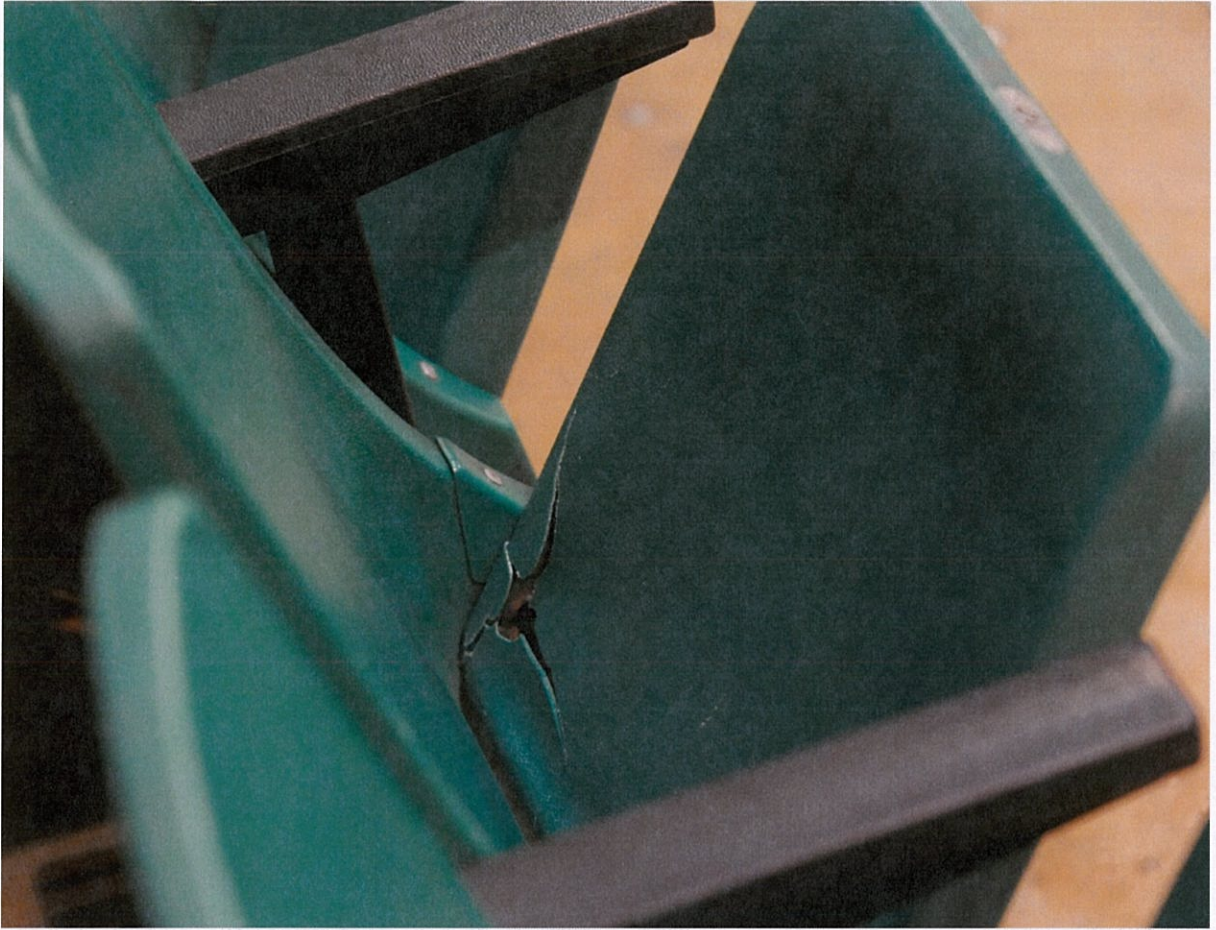







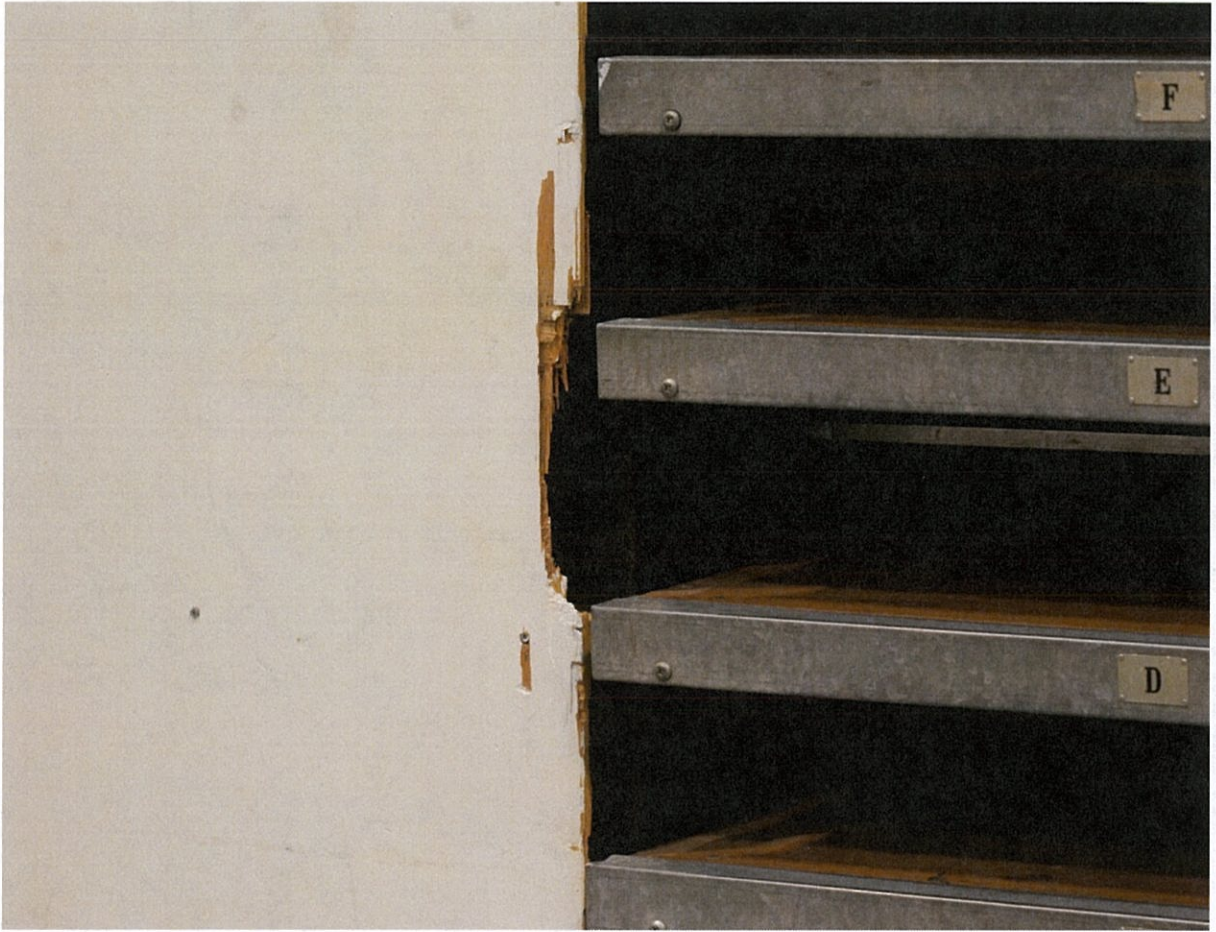











**COMMUNITY DEVELOPMENT COMMITTEE APPLICATION  
AND REQUEST FORM FOR USE OF SALES TAX PROCEEDS FOR  
COMMUNITY FACILITIES**

**INTRODUCTION**

Pursuant to Ordinance No. 4380 of the Minot Code of Ordinances, the City of Minot may make proceeds available from the city sales tax for purposes of upgrading, remodeling and constructing community facilities. These community facilities, for example, may be constituted by arenas, auditoriums, and facilities for conventions, tourist and sporting events. Community facilities must meet one of the following three categories in order to be eligible for possible funding: (1) community facilities owned directly by the City of Minot; (2) community facilities owned directly by another county, city, township, city park district, school district, or other political subdivision of the state of North Dakota, including any agency, board, or institution of the state of North Dakota, and for which entities an appropriate Joint Powers Agreement has been lawfully executed between the City of Minot and the applicable entity; and (3) community facilities of private non-profit entities with which the City of Minot has authority to engage in with respect to a lawful business or enterprise under North Dakota law meeting a public purpose and for which an independent and applicable implementing Ordinance has been passed by the City, and which lawful business or enterprise is predicated upon subsequent written agreement sufficiently detailed to ensure supervisory controls and measurable analysis that the public purpose is being met.

The filing of an application or request form is not intended to guarantee an award or granting of sales tax proceeds to an applicant. The City of Minot reserves the right to approve or reject applications and projects on a case by case basis, taking into consideration established policies, project criteria, and demand on City services and finances in relation to the potential benefits from the project. In the consideration of submitted applications, the City will address the specific and unique needs of the community as a whole and will review the submitted applications in terms of serving the best interests of the community. Approval or denial of one project is not intended to set precedence for approval or denial of another project. The City of Minot shall also consider whether funding of an identified project results in unfair advantage or constitutes unfair competition, if applicable, with similar competitors or other like businesses.

The City of Minot may also request additional information which is deemed necessary in the consideration and determination of a submitted application. Finally, applicants should note that all information submitted with respect to an application or request for sales tax proceeds in the construction, enhancement or improvement of community facilities, is subject to public disclosure, and that the City does not guarantee the confidentiality of the information submitted in the application process.



APPLICATION/REQUEST

**Name of Organization/Facility:** Roosevelt Park Zoo/Minot Park District

**Contact Person/Spokesperson:** Becky Dewitz, Zoo Director and Ron Merritt, MPD Executive Director

**Address:**

Minot Park District  
PO Box 538  
Minot, ND 58702

**Telephone No:** (701) 857-4136

---

**Type of Organization/Facility:**

City/Public

Private Non-Profit

Another Governmental Entity

**List of Applicant's Governing Board/Supervisor:**

Cliff Hovda, Minot Park Board President  
Ron Merritt, Minot Park District Executive Director

---

**Physical Location of Project:**

Roosevelt Park Zoo  
1219 Burdick Expy E  
Minot, ND 58701

---

**Please describe this project and its benefits, and also explain how it relates to the community of Minot (for example: a description of the project or service; an outline of the project goals and intended results; a description of the economic impact of the project on the community; a projected time table for completion of the project; an explanation of how the City of Minot will benefit from the expenditure of sales tax proceeds for the project or service; and an explanation of how the outcome or success of the project will be evaluated or measured):**

Organization Information

The Roosevelt Park Zoo is the oldest zoo in North Dakota having been established in 1919 with a lone bison from Montana. The iconic Zoology building was built in 1921 and was the heart of the zoo showcasing a menagerie of animals from around the world including African lions, primates, alligators,

and more. Progressive citizens wanted a zoo in Minot to enrich their community and offer a unique experience to all who visited the Roosevelt Park Zoo.

Our community-owned zoo has endured through two major floods. The 1969 flood is often referred to as “a blessing in disguise”. The 1969 flood transformed the future of Roosevelt Park Zoo as the community rallied to rebuild and improve the zoo. The Greater Minot Zoological Society (DBA: Minot Zoo Crew) was founded in 1970 as the support organization partnering with the Minot Park District to support Roosevelt Park Zoo.

Our mission is to “Let the World Surround you at Roosevelt Park Zoo”. We strive to provide education, experiences, and knowledge promoting wildlife understanding, education, conservation and an intrinsic, personal connection with the natural world.

During the 2011 flood, again our community rallied to support their local zoo. Volunteers helped evacuate the animals side by side the zoo staff. All the animals were successfully and safely evacuated. We re-opened in 2013 after Park District and Zoo staff, construction workers and volunteers worked arduously to rebuild the zoo. We have completed our efforts to rebuild the zoo and now we look to develop the zoo and meet the growing needs of our community.

### Project Summary

We are requesting \$3 million dollars from the City’s Facility Grant Fund to build new habitats for the big cats at Roosevelt Park Zoo. The total project cost is \$5 million dollars and consists of 3 separate projects: Amur Tiger habitat (\$1.9 million), African Lion habitat (\$2.1 million), and Cat complex for Amur leopards and Snow leopards (\$1 million). Both the tiger and lion habitats would be newly constructed exhibits featuring naturalistic landscapes for the enrichment of the animal as well as provide a dynamic and educational experience for our visitors. The cat complex would be a renovation of the existing habitat and will feature rock climbing structures and overhead catwalks to again provide an enriching home for the animals and unique visitor experience.

### Project Description

The Minot Park District and Minot Zoo Crew are partnering to improve our zoo with major capital investments. We look back on our history as inspiration to guide our future. Prior to the 2011 flood, we had master plan goals to address aged infrastructure. Our focus was on exhibits built in the 1970s following the devastation of the 1969 flood namely: our cat complex, bear den and primate exhibits. These exhibits are antiquated and no longer meet modern zoological standards in terms of design and theory.

These projects would improve our animals’ quality of life and welfare. The project would provide larger, naturalistic and enriching habitats to encourage natural behavior of the animals and meet their species-specific needs. Modern zoo theory and design not only addresses the component of animal welfare but, also the visitor experience. Zoo visitors will gain understanding and appreciation of the animals who serve as ambassadors for their wild counterparts. We will work to further our visitor’s understanding with educational signage highlighting habitat awareness and conservation initiatives to help save animals from extinction.

Project Impact for our Community

This grant would be immediately impactful and serve as our anchor gift to propel our capital campaign fundraising strategy. The grant funding would also provide us the opportunity to break ground on the Amur Tiger habitat in 2018.

The Roosevelt Park Zoo boasts over 90,000 visitors annually. Through informal and formal education programs, we reach over 10,000 children in our community and surrounding region. We have been awarded the Visit Minot's "Favorite Destination" award for five consecutive years, TripAdvisor's Certificate of Excellence in 2015 and Minot Daily News Reader's Choice Award winner for favorite "Local Attraction" for over 10 years. Through our strategic plan completed in 2016, our consultants identified the Roosevelt Park Zoo as one of the most loved and recognizable cultural entities of our City. It is our objective to provide a high-quality zoo for our community that enriches our community's culture, engages our children and families while also striving to provide the highest level of care for our animals. We offer numerous events throughout the year for families, children and tourists.

We are dedicated to improving and modernizing our Zoo. The Minot Park District and Minot Zoo Crew have never taken on a capital project of this size and are financially committed to its success. Beyond the zoo campus, we are investing in our community youth and have hired a full-time educator to grow our educational presence to area children. The Zoo is a living institution for wildlife and conservation education in our region. We have a tradition and legacy as the best zoo in North Dakota. This grant would help propel us to be the best small zoo in the Nation and certainly in a population size of Minot, the Magic City. We will celebrate our centennial in 2021, proud of our past and optimistic of our future.

**If available, please describe and attach diagrams or schematic designs of the requested project:**

Please see the attached renderings of the project in sequential order of project construction. 1) Amur Tiger River Valley 2) African Lion Savannah and 3) Big Cat Country. A site map is also included to detail each habitats location.

---

**Specific amounts requested from the City of Minot and dates requested:**

\$3 million

---

**Describe any alternative sources of funding, other than the City of Minot, which will be pursued with respect to this project (please indicate whether those sources are presently confirmed or tentative funding sources):**

This project will launch our \$5 million capital campaign effort. We will be seeking philanthropic support for the remainder of funding required. Should our campaign goal not be achieved, we will acquire a loan to finance the remaining balance. The Minot Park District and Minot Zoo Crew have a long and successful history of partnering together to improve the zoo. This project will accomplish of first phase of major development addressing aged infrastructure. We are in the initial stages of planning for future projects for our bears and primates.

**Please list any other information that the applicant believes should be considered by the City of Minot in the determination of this request:**

Roosevelt Park Zoo is accredited by the Association of Zoo's and Aquariums (AZA). Only 230 zoos and aquariums in our Nation have achieved this highest accreditation process which consists of a satisfying the qualitative evaluation and professional standards of the AZA Accreditation Commission. The Zoo is subject to accreditation inspections every 5 years. At our last accreditation hearing, the AZA gave us stern warning that our aged facilities must be addressed and we could risk loss of accreditation should we not show significant strides towards modernization. There are numerous benefits to being an AZA-accredited zoo. We can network and share knowledge with some of the largest zoo leaders such as Bronx Zoo, San Diego Zoo, Henry Doorly Zoo and many more. AZA zoos work collaboratively to preserve genetic integrity of species through well-managed breeding programs called Species Survival Programs (SSP). Many of our zoo animals are in Minot on permanent loan or breeding recommendations of SSP. Loss of accreditation could result in zoos requesting their animals back as they many zoos prefer to work only with other AZA zoos as accreditation means high quality of care. We are due for our next accreditation cycle in 2019.

#### CERTIFICATION OF APPLICATION

The undersigned hereby certifies that both they and the entity listed in this application, and the specific request herein for the use of sales tax proceeds for community facilities, does not, and will not discriminate in its plans, programs, and activities on the basis of race, color, national origin, creed, religion, age, sex, handicap or any other basis which has been declared as discriminatory by federal or state cases or law.

Date: 5/17/17

Signature: 

(Title/Position) Ex. Director



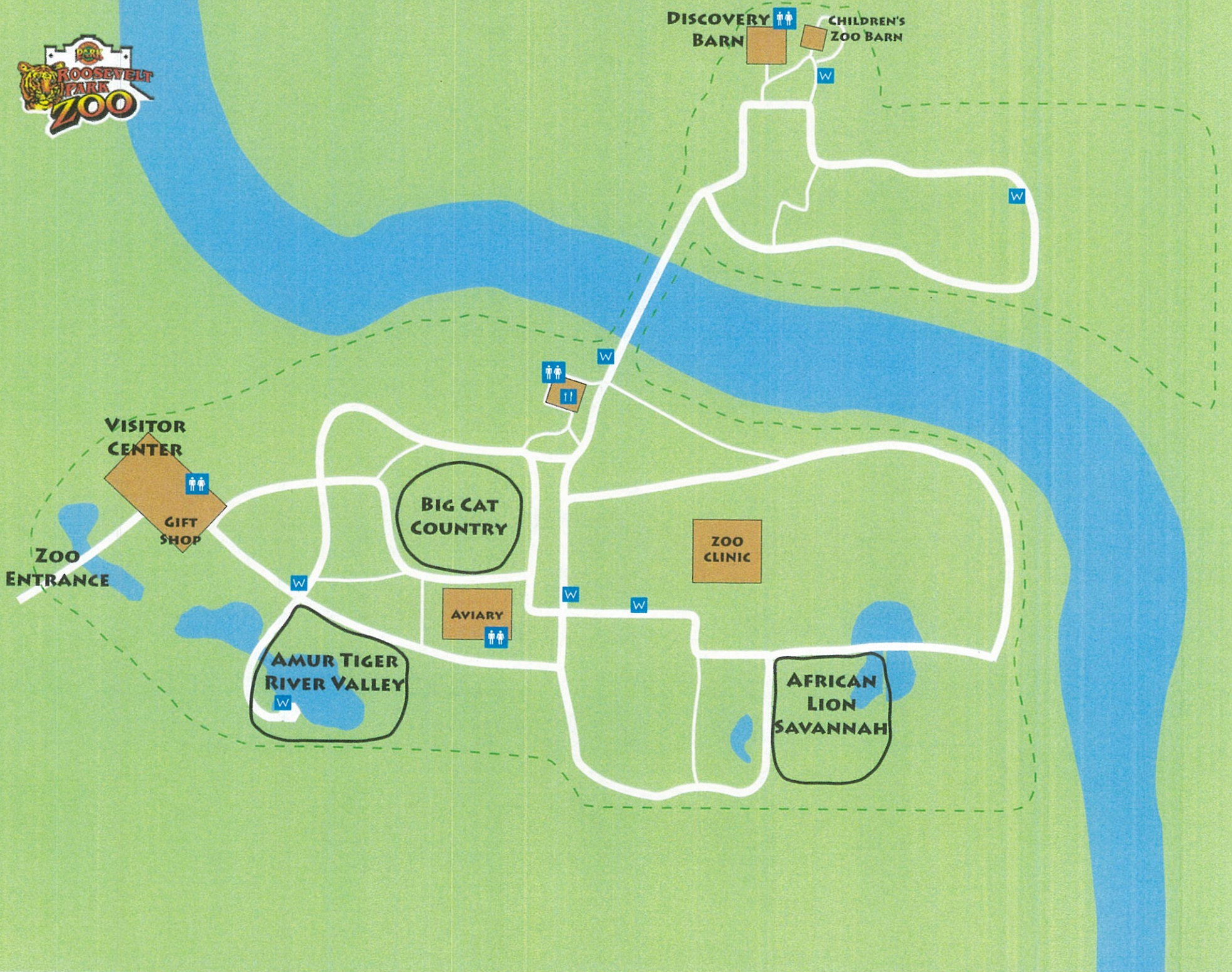



## ROOSEVELT PARK ZOO AMUR RIVER EXHIBIT

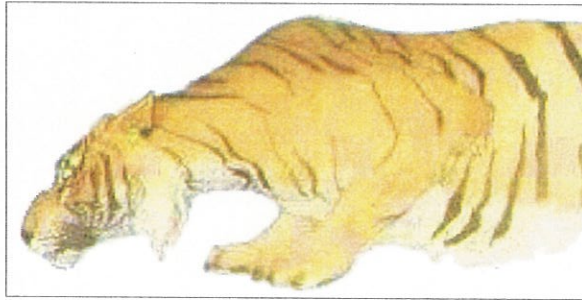

### MINOT NORTH DAKOTA

THE ROOSEVELT PARK ZOO HAS DISPLAYED TIGERS SINCE THE 1970s. ALTHOUGH THE CURRENT HOUSING AND DISPLAY FACILITIES ARE ADEQUATE, THEY LACK BOTH THE SPACE FOR BREEDING AND MANY ANIMAL CARE AMENITIES THAT HAVE BEEN DEVELOPED IN THE PAST DECADES. SURVEYS INDICATE THE RPZ CAT EXHIBITS ARE RANKING HIGH AS CONCERNS SHARED BY THE RPZ VISITORS AND GUESTS.

AS A STEP FORWARD WE HOPE TO ADD A NEW AMUR TIGER EXHIBIT TO THE ZOO.

AMUR TIGERS (SIBERIAN TIGERS) ARE THE LARGEST OF THE CAT SPECIES.

INDEED THE LARGEST TO LIVE ON OUR PLANET.

THEY ARE PARTICULARLY WELL ADAPTED TO COLD ENVIRONMENTS.

MAKING THEM A EXCELLENT CHOICE FOR NORTH DAKOTA.

AMUR TIGERS WERE DRIVEN CLOSE TO EXTINCTION IN THE 1940s

THE POPULATION WAS ESTIMATED AS LOW AS 40 ANIMALS IN THE WILD.

WITH A COMBINATION OF PROTECTION PROGRAMS AND GEO-POLITICAL EVENTS,

THE POPULATION IS NOW ESTIMATED AT 450 ANIMALS.

TYPICAL OF DRASTIC POPULATION CHANGES, TODAY'S POPULATION IS THREATENED BY LOW GENETIC DIVERSITY.

WITH A SUCCESSFUL SHARED RESOURCES BREEDING PROGRAM WITHIN THE AZA ZOOS  
A VIABLE CAPTIVE POPULATION WOULD HAVE GREAT BEARING ON THE WILD POPULATION.

THE NEW AMUR TIGER EXHIBIT AT ROOSEVELT PARK ZOO WOULD UTILIZE CURRENT RESOURCES  
WOULD ADDRESS CURRENT PUBLIC PERCEPTION, ADD A GREAT VISITOR EXPERIENCE,  
AND ALSO ALLOW US TO JOIN A PROGRAM WITH TREMENDOUS CONSERVATION POTENTIAL.

ROOSEVELT PARK ZOO, AMUR RIVER EXHIBIT

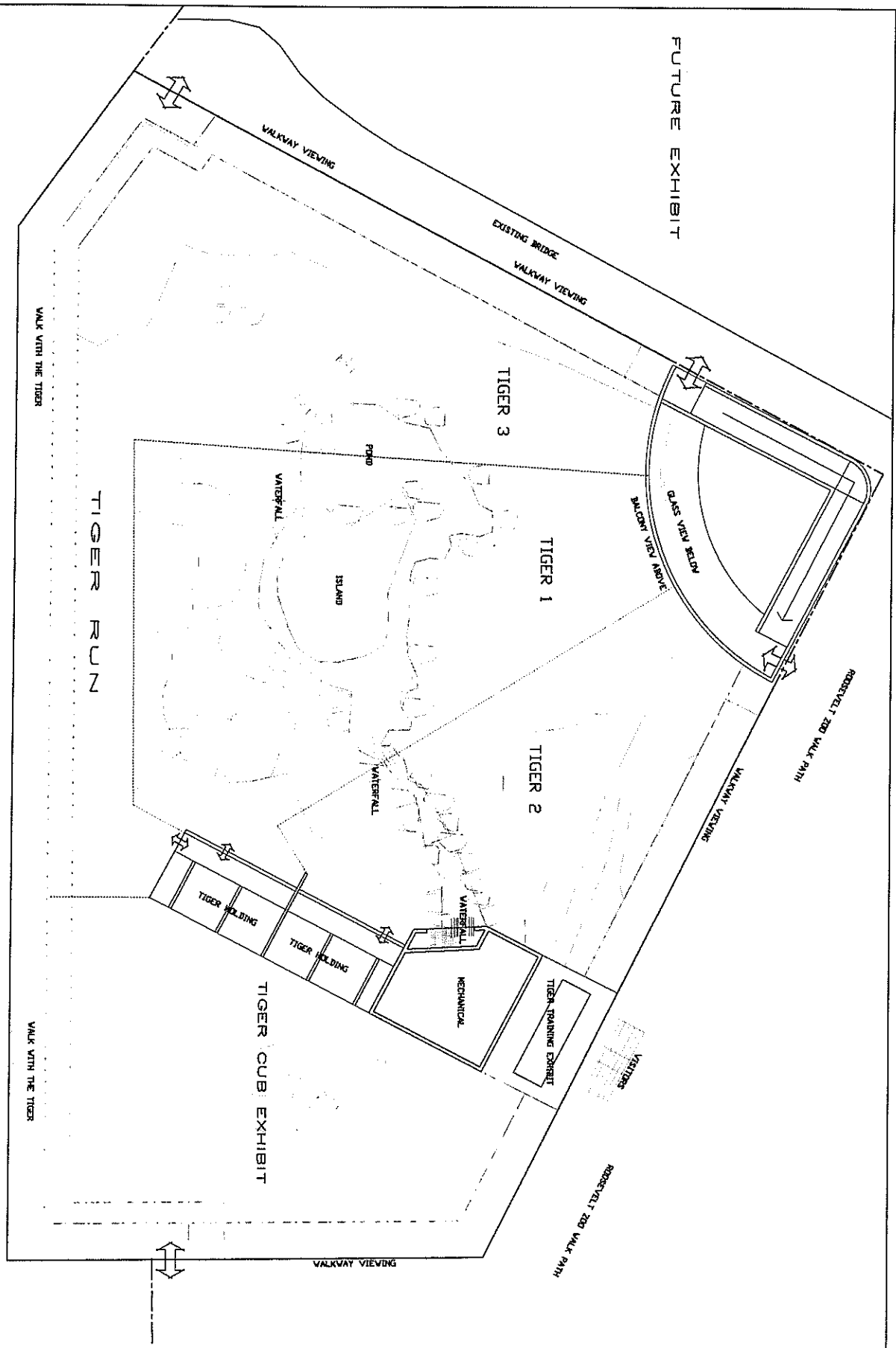

SHEET  
A2  
OF 2

Minot Park District  
Zoo File  
Minot, North Dakota

Tiger Exhibit Concept #1

ANDERSON, WADE, WHITTY P.C.  
ARCHITECTS & PLANNERS  
MINOT, NORTH DAKOTA

DRAWN BY CLM  
CHECKED BY  
JOB NUMBER 000-13

DATE  
Feb.  
2013



# AMUR TIGER RIVER VALLEY

*Location: existing duck pond near Visitor Center entrance*





# AMUR TIGER RIVER VALLEY

*Location: existing duck pond near Visitor Center entrance*

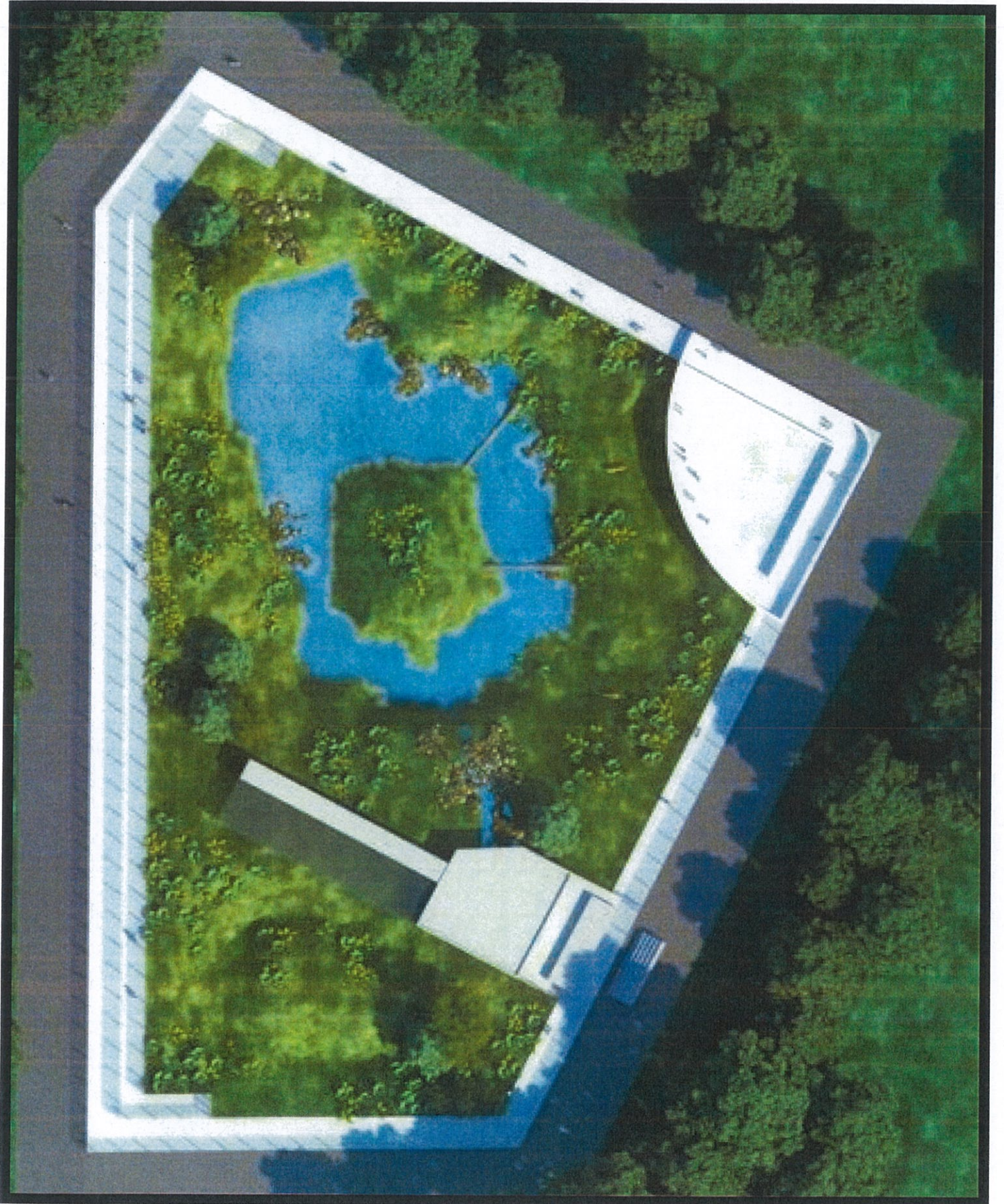



# AFRICAN LION SAVANNAH

*Location: existing camel habitat—old Alan Kurth building on Burdick is pictured in the background*

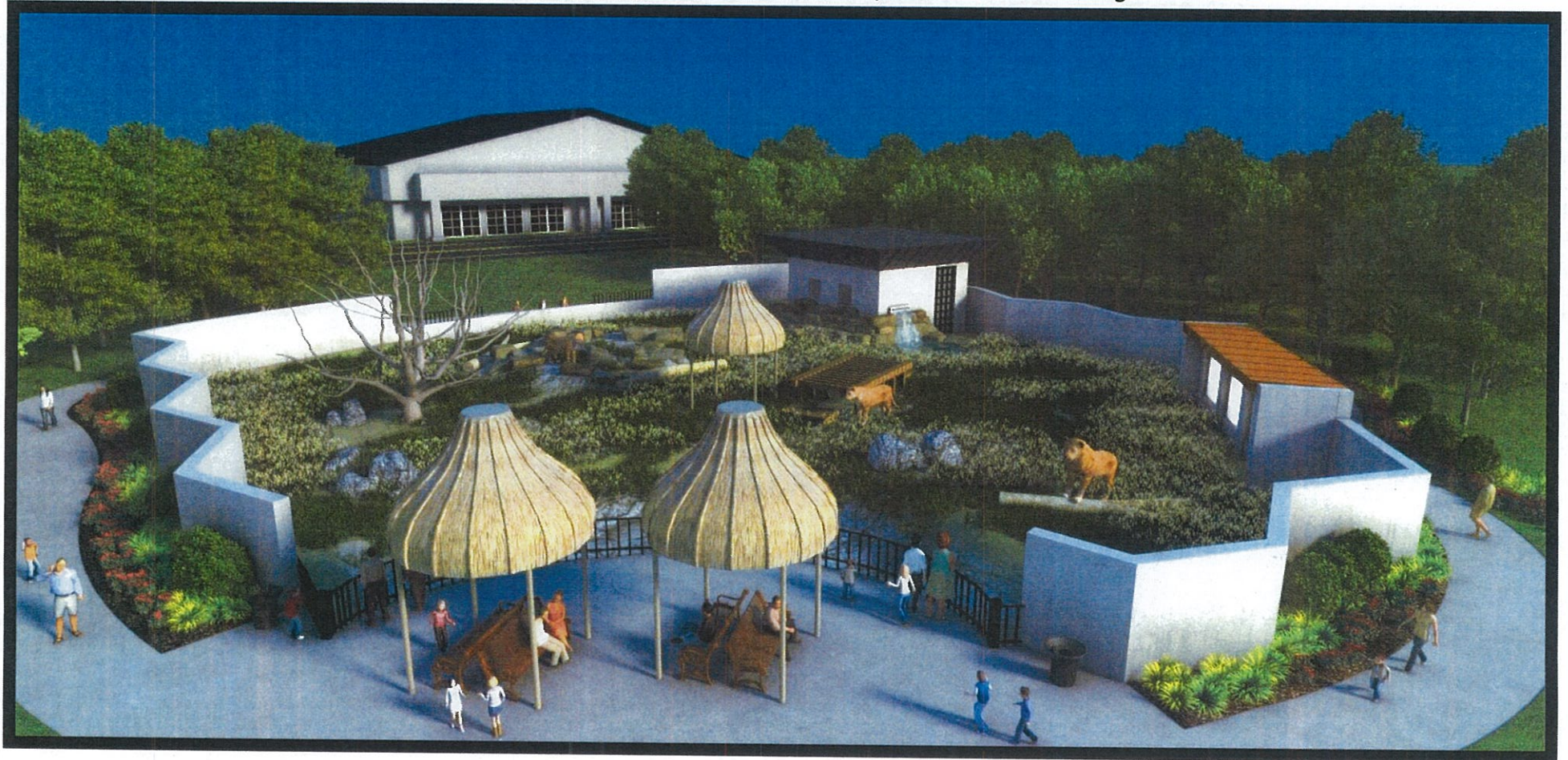

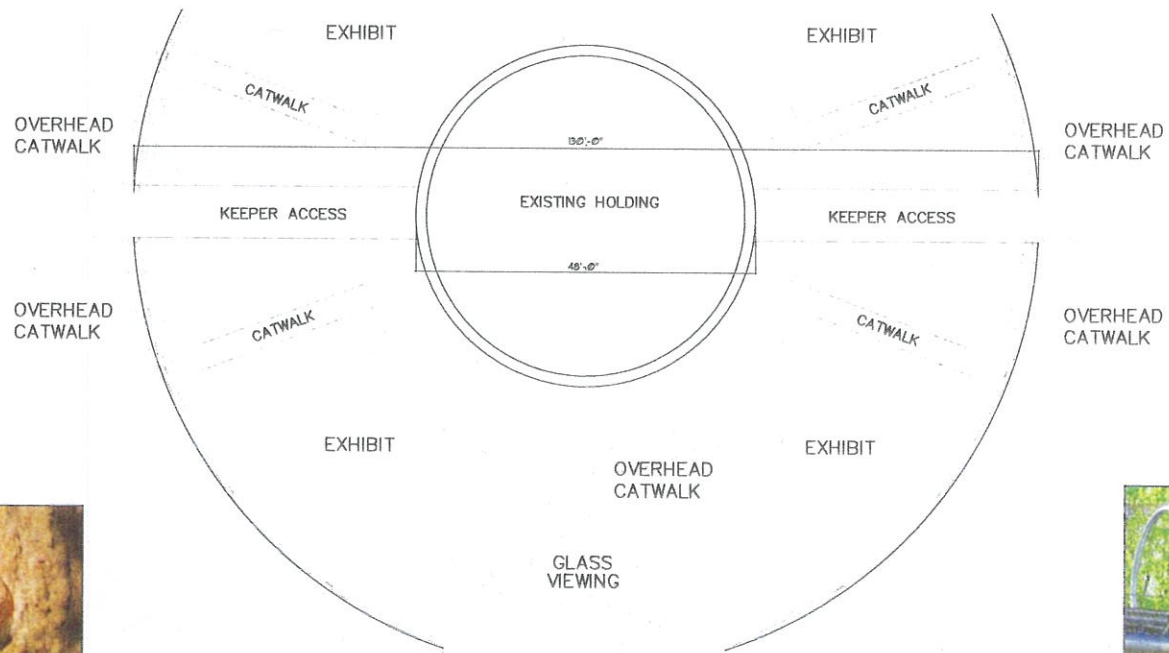

FELINE

EXHIBIT



FELINE

CATWALK

PRELIMINARY PLAN  
SIMILAR OPPOSITE SIDE

FELINE EXHIBIT ROOSEVELT PARK ZOO

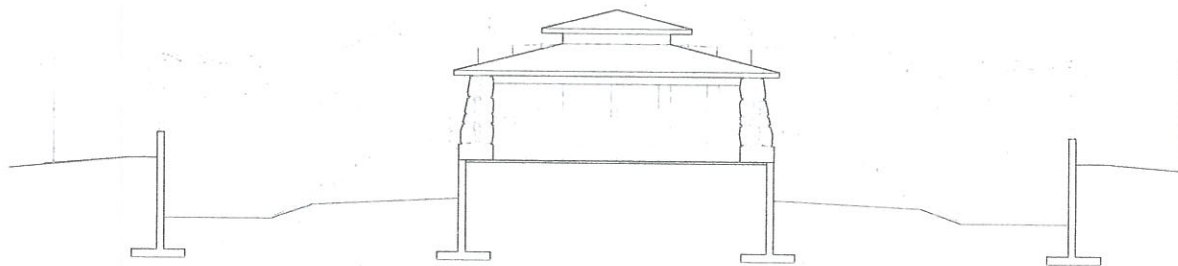

PRELIMINARY SECTION  
SIMILAR OPPOSITE SIDE





# BIG CAT COUNTRY

*Renovation of existing cat complex*

*Includes catwalks for climbing cat species, i.e. Amur & Snow Leopards*





# BIG CAT COUNTRY

*Renovation of existing cat complex—includes catwalks for climbing cat species*

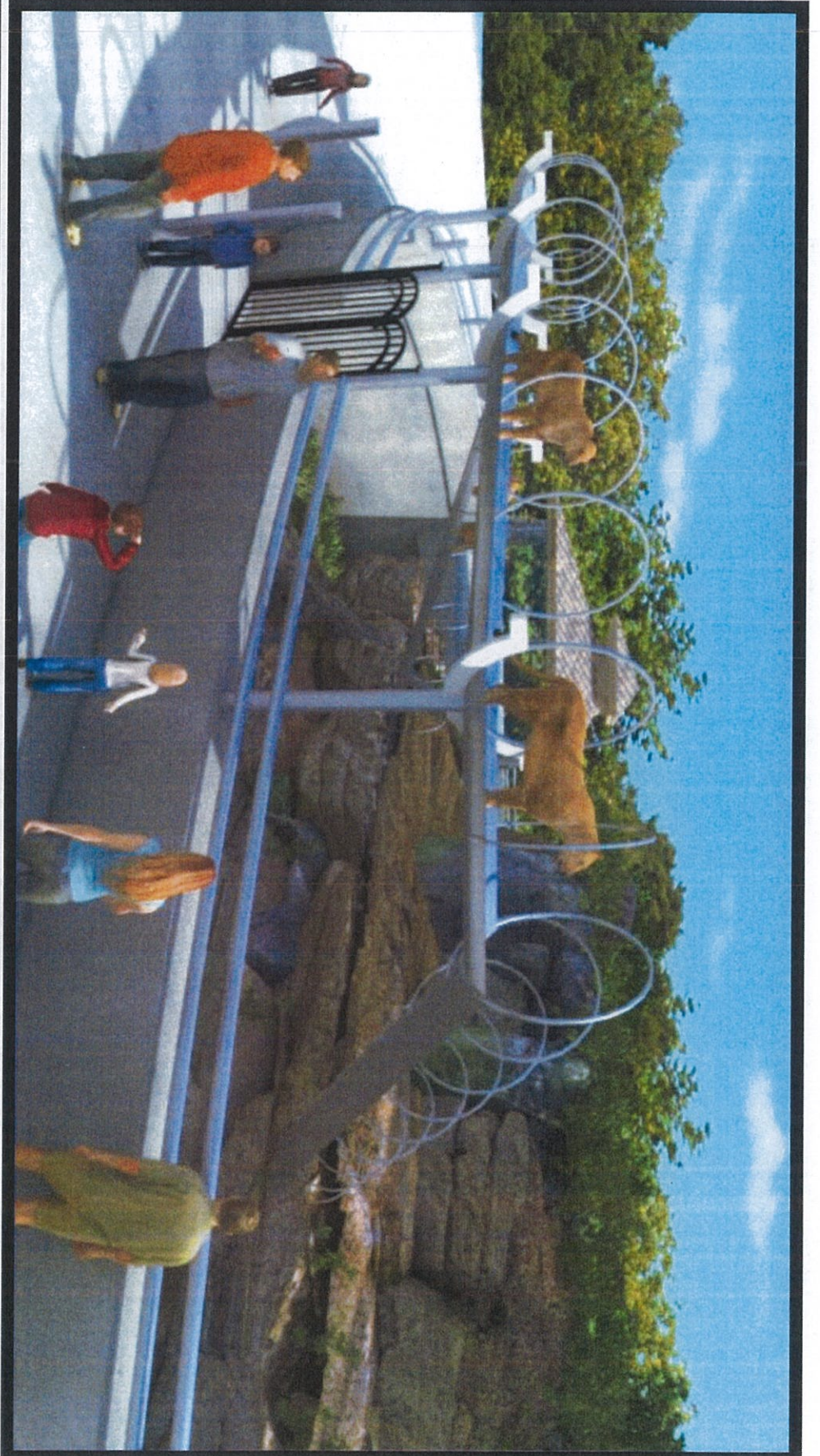
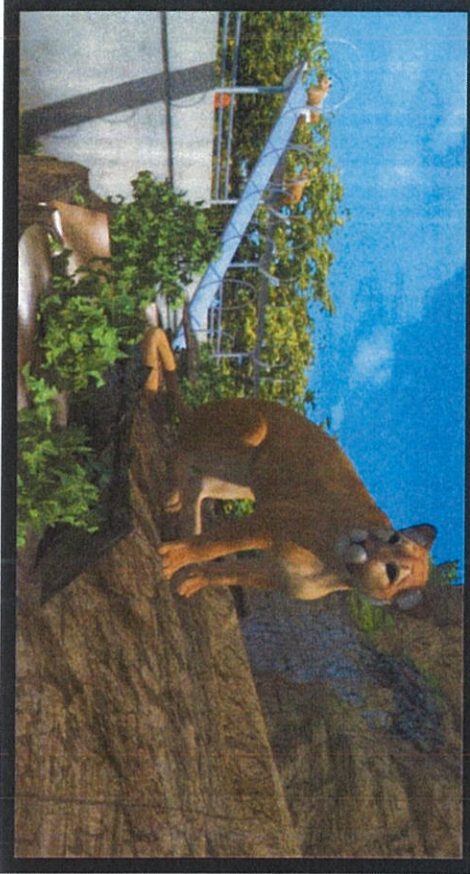



# BIG CAT COUNTRY

*Renovation of existing cat complex—includes catwalks for climbing cat species*

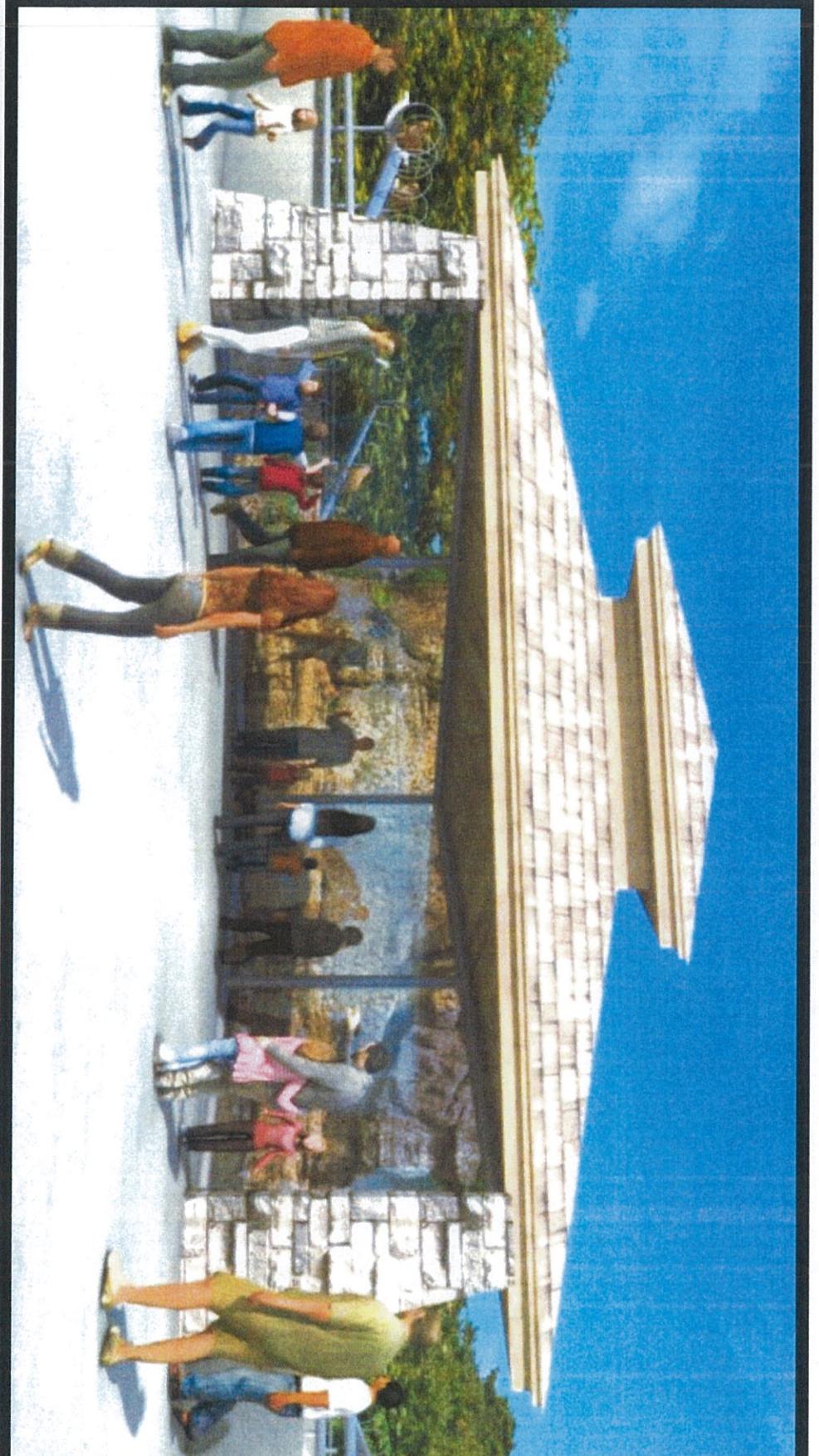
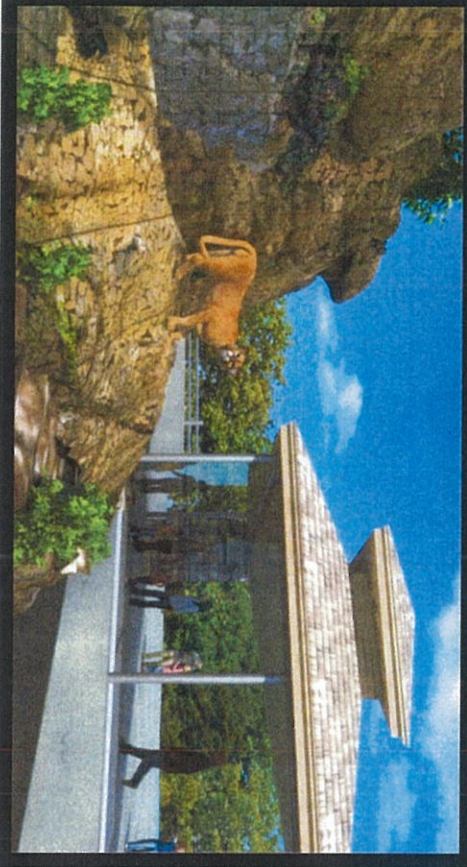



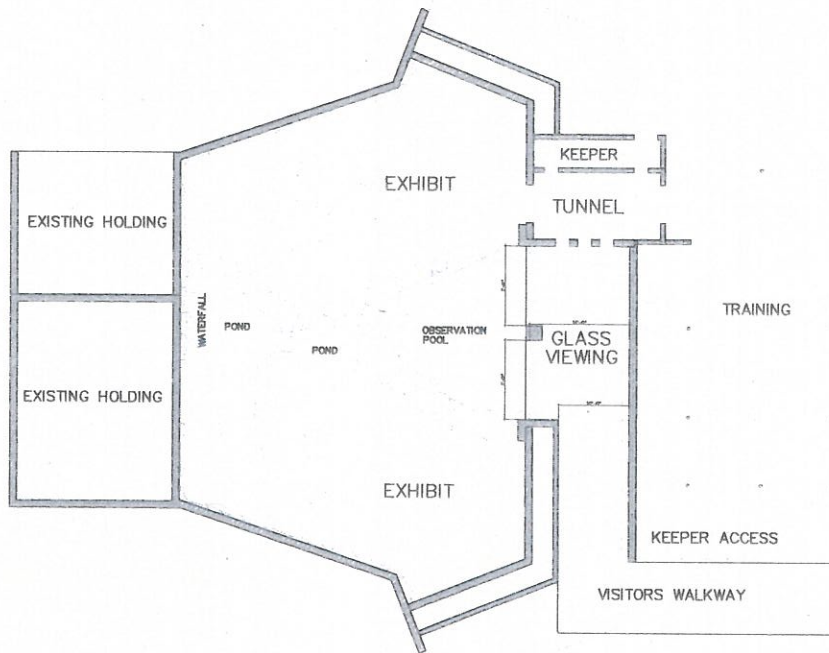

PRELIMINARY PLAN

BEAR DEN EXHIBIT ROOSEVELT PARK ZOO  
EXPANSION AND RENOVATION

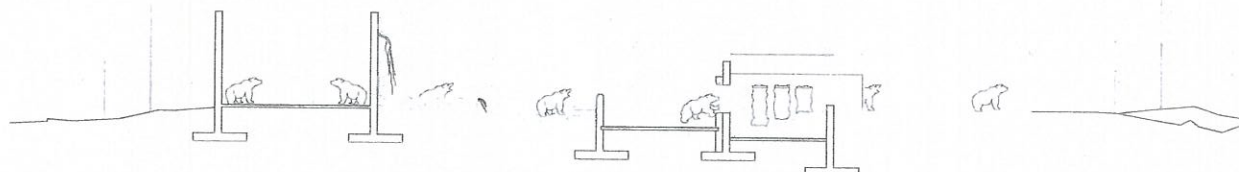

PRELIMINARY SECTION  
SIMILAR OPPOSITE SIDE

ANDERSON, WADE WHITTY  
ARCHITECTS MINOT ND





PRIMATE

EXHIBIT



PRIMATE

EXHIBIT

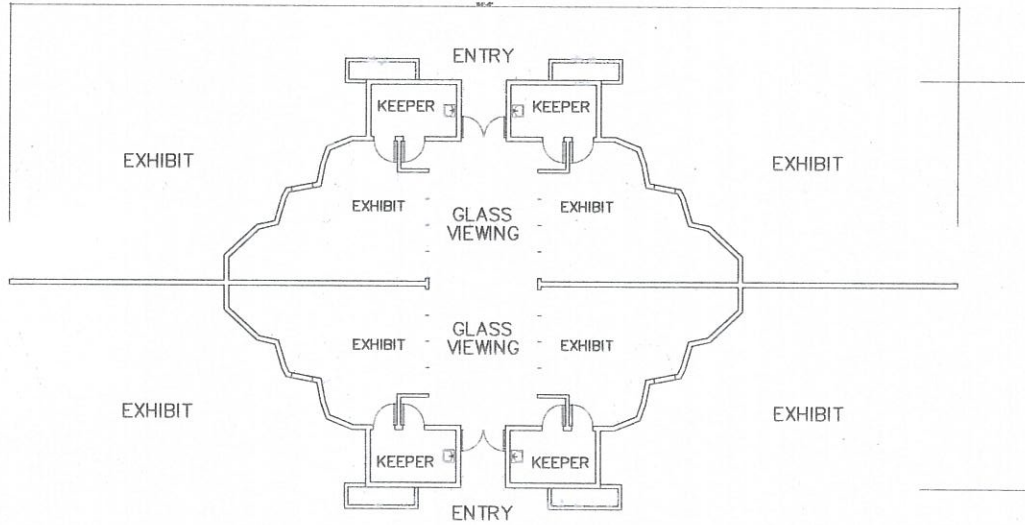

PRELIMINARY PLAN

PRIMATE EXHIBIT ROOSEVELT PARK ZOO

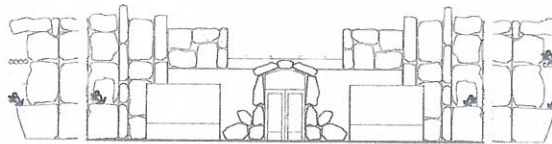

PRELIMINARY ELEVATION  
SIMILAR OPPOSITE SIDE

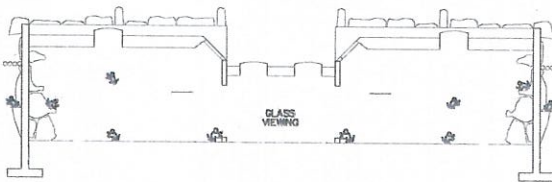

PRELIMINARY SECTION  
SIMILAR OPPOSITE SIDE

COMMUNITY DEVELOPMENT COMMITTEE APPLICATION AND  
REQUEST FORM FOR USE OF SALES TAX PROCEEDS FOR  
COMMUNITY FACILITIES

INTRODUCTION

Pursuant to Ordinance No. 4380 of the Minot Code of Ordinances, the City of Minot may make proceeds available from the city sales tax for purposes of upgrading, remodeling and constructing community facilities. These community facilities, for example, may be constituted by arenas, auditoriums, and facilities for conventions, tourist and sporting events. Community facilities must meet one of the following three categories in order to be eligible for possible funding: (1) community facilities owned directly by the City of Minot; (2) community facilities owned directly by another county, city, township, city park district, school district, or other political subdivision of the state of North Dakota, including any agency, board, or institution of the state of North Dakota, and for which entities an appropriate Joint Powers Agreement has been lawfully executed between the City of Minot and the applicable entity; and (3) community facilities of private non-profit entities with which the City of Minot has authority to engage in with respect to a lawful business or enterprise under North Dakota law meeting a public purpose and for which an independent and applicable implementing Ordinance has been passed by the City, and which lawful business or enterprise is predicated upon subsequent written agreement sufficiently detailed to ensure supervisory controls and measurable analysis that the public purpose is being met.

The filing of an application or request form is not intended to guarantee an award or granting of sales tax proceeds to an applicant. The City of Minot reserves the right to approve or reject applications and projects on a case by case basis, taking into consideration established policies, project criteria, and demand on City services and finances in relation to the potential benefits from the project. In the consideration of submitted applications, the City will address the specific and unique needs of the community as a whole and will review the submitted applications in terms of serving the best interests of the community. Approval or denial of one project is not intended to set precedence for approval or denial of another project. The City of Minot shall also consider whether funding of an identified project results in unfair advantage or constitutes unfair competition, if applicable, with similar competitors or other like businesses.

The City of Minot may also request additional information which is deemed necessary in the consideration and determination of a submitted application. Finally, applicants should note that all information submitted with respect to an application or request for sales tax proceeds in the construction, enhancement or improvement of community facilities, is subject to public disclosure, and that the City does not guarantee the confidentiality of the information submitted in the application process.

APPLICATION/REQUEST

Name of Organization/Facility:

Souris Valley Animal Shelter  
1935 20<sup>th</sup> Ave SE Minot, ND 58701  
701-852-6133

Contact Person:

Randy McDonald  
1935 20<sup>th</sup> Ave SE Minot, ND 58701  
701-852-6133

Type of Organization/Facility:

Private Non-Profit

List of Applicant's Governing Board:

See attached document

Physical Location of Project:

1935 20<sup>th</sup> Ave SE Minot, ND 58701

Please describe this project and its benefits, and also explain how it relates to the community of Minot:

The Souris Valley Animal Shelter (SVAS) has developed plans to remodel and expand to better suit the needs of the City of Minot and Ward County. The primary purpose of this expansion will focus on increasing our housing capabilities to reduce the number of feral/stray pets within the city of Minot and Ward County. This project will also include the addition of a spay/neuter clinic (the only clinic of its kind found WITHIN an animal shelter in North Dakota). The clinic will serve three purposes. The main purpose will focus on the SVAS's current pets. The next purpose is its Trap/Neuter/Release (TNR) program which focuses on sterilizing feral cats in our community to control reproduction. Finally, the SVAS will offer low income spay/neutering.

The addition of a 44'X34' multi-purpose room will enable the SVAS to expand the capacity of care in times of crisis for both the City and citizens in need of emergency sheltering. Additionally, the room will allow us to expand our community programs. The introduction of programs such as therapy dogs, emergency sheltering, humane education, and the "Read to the Animals" program have been very well received in the community. The therapy dog program partners with the Domestic Violence Crisis Center, the YWCA, the Men's Winter Refuge, and most assisted living facilities and retirement homes in the Minot community. Pre-screened animals are brought to scheduled destinations to allow residents an hour to interact with the SVAS pets. This gives the pets much needed socialization and exercise while at the same time providing comfort to the most vulnerable.

The SVAS created emergency sheltering to provide peace of mind during times of crisis. For example, 48% of Domestic Violence victims will not leave their situation due to the fear of what might happen to their pet if they do. The YWCA and the Men's Winter Refuge view pet ownership as a barrier to homeless sheltering. Additionally, the Red Cross can house victims and their families in times of emergency but not their pet.

The SVAS's collaboration has eliminated these barriers to the people and families experiencing these crises. Finally, with grant funding and partnership with local businesses, the SVAS is establishing a



gift card program intended for pet retention. An example of when the gift card would be necessary would be when the victims of domestic violence escape they often leave with absolute minimum they need i.e....kids, pets. This gift card will offer \$100 to purchase the pet essentials such as food, bowls, leashes, collars, litter and similar necessities. Partnering businesses will offer discounts on these items to ensure the money stretches to purchase all needed items.

If possible, please describe and attach diagrams, or schematic designs of the requested project:

The project will consist of 2 separate phases. Phase 1 will be the addition of nearly 7,000 square feet on the back of our property. This phase will include a 44'X34' multi-purpose room, overflow housing, upgraded mechanical rooms, the separation of cats and dogs, a dog daycare/groomer (this area will provide funding for the spay/neuter clinic) and an after-hours surrender area. Phase 2 will remodel the existing building to better utilize space. This remodel will include the addition of the Spay/Neuter Clinic, better drainage, better air circulation, additional adoption /Read to the Animals rooms.

Specific amounts requested from the City of Minot and dates requested:

Amount requested is \$900,000 in order to partially fund Phase 1; Date requested is January 15, 2018

Describe any alternative sources of funding, other than the City of Minot, which will be pursued with respect to this project (also indicate whether those sources are presently or tentative funding sources):



Currently the SVAS has raised \$466,000. This amount is a combination of donated money and promised services. The Farsted Foundation, Base Utilities, Ackerman-Estvold, and Dakota Fence have all pledged or delivered services/funding.

Please list any other information which the applicant believes should be considered by the City of Minot in the determination of this request:

The city wide implementation of the Trap/Neuter/Release program and the SVAS's inclusion during the Emergency Animal Sheltering discussion illustrates the growth in its reputation and service to the community. The SVAS has 40 years of service in the City of Minot and Ward County including emergency housing and care during times of need. Over the past three years it has made a concentrated effort to strengthen the bonds with community leaders. An increased social media presence and the recent addition of a Community Outreach Coordinator highlight the commitment by the SVAS to further grow in its service to the community. This recognition within the community has enabled the SVAS to partner with the Home Depot and other agencies on multiple occasions to address unexpected needs of the SVAS. Donated material and time have led to the construction of a new outdoor kenneling roof and the design of a wheelchair for a disabled puppy.

#### CERTIFICATION OF APPLICATION:



The undersigned hereby certifies that both they and the entity listed in this application, and the specific request herein for the use of sales tax proceeds for community facilities, does not, and will not discriminate in its plans, programs, and activities on the basis of race, color, national origin, creed,

religion, age, sex, handicap, or any other basis which has been declared as discriminatory by federal or state cases or law.

Date 6/30/2017

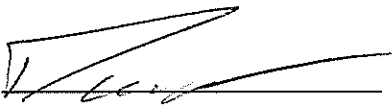
Signature: 

Title/Position: Shelter Director

# **SOURIS VALLEY ANIMAL SHELTER BOARD OF DIRECTORS**

<p><b>Kris Warmoth – President 2019</b>          1700 Terrace Drive          Minot ND 58703          (H) 701-240-9108 - (W) 701-858-3168  <a href="mailto:kris.warmoth@minotstateu.edu">kris.warmoth@minotstateu.edu</a>          Dean for the Center for Extended Learning          Minot State University</p>	<p><b>Sheila Miller – Secretary 2017</b>          812 15 ½ Ave SE          Minot ND 58701          (H) 701-852-4964          (C) 701-240-4319  <a href="mailto:smiller1266@gmail.com">smiller1266@gmail.com</a>          VP Finance and Facilities          Dakota Boys and Girls Ranch</p>
<p><b>Jessica Donamaria –Director 2017</b>          1513 University Ave NW          Minot, ND          (C) 701-720-5927          (H) 701-852-2345  <a href="mailto:jessica.donamaria@gmail.com">jessica.donamaria@gmail.com</a>          Travel Agent          Preferred Travel</p>	<p><b>Mason Cool – Director 2019</b>          808 15 ½ Ave SE          Minot, ND 58701          701-340-9462  <a href="mailto:masoncool@gatecitybank.com">masoncool@gatecitybank.com</a>          Assistant Vice President          Mortgage Loan Officer          Gate City Bank</p>
<p><b>Jenn Burdick – Director 2018</b>          2003 12<sup>th</sup> St NW          Minot ND 58703          701-340-2001  <a href="mailto:burdickjenn@gmail.com">burdickjenn@gmail.com</a>          Behavior Strategist          Minot Public Schools</p>	<p><b>Laura Thomas – Director 2019</b>          3003 11<sup>th</sup> St SE          Minot ND 58701          (C) 701-833-2275  <a href="mailto:lauradubya@gmail.com">lauradubya@gmail.com</a>          Director of Human Resources          Kalix</p>
<p><b>Emily Schenfisch –Director 2018</b>          5 Briar Drive          Velva, ND 58790          (H) 229-563-2626          (W) 701-837-2234  <a href="mailto:eschenfisch@firstintlbank.com">eschenfisch@firstintlbank.com</a>          Assistant Loan Operations Manager          First International Bank</p>	<p><b>Leann Weber Mellum –Director 2018</b>          Minot, ND          (C)701-739-6051  <a href="mailto:leannmellum@hostfest.com">leannmellum@hostfest.com</a>          Marketing Director          Norsk Hostfest</p>
<p><b>Kami Hanson –Director 2017</b>          808 18<sup>th</sup> St NW          Minot, ND 58703          (H) 701-721-5401 – (W) 701-838-0081  <a href="mailto:kami.ncm@gmail.com">kami.ncm@gmail.com</a>          Manager          North Country Mercantile</p>	
<p><b>Russ Gohl</b>  <b>Associate Director</b>          Owner          Base Utility</p>	<p><b>Mia Farstad</b>  <b>Associate Director</b>          Marketing Director          Minot Area Development Corporation</p>



**UPPER LEVEL** 

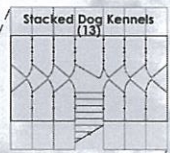

- Legend**
-  dogs
  -  cats
  -  circulation
  -  staff
  -  support spaces
  -  vet services
  -  multi-purpose
  -  overflow
  -  pet boarding

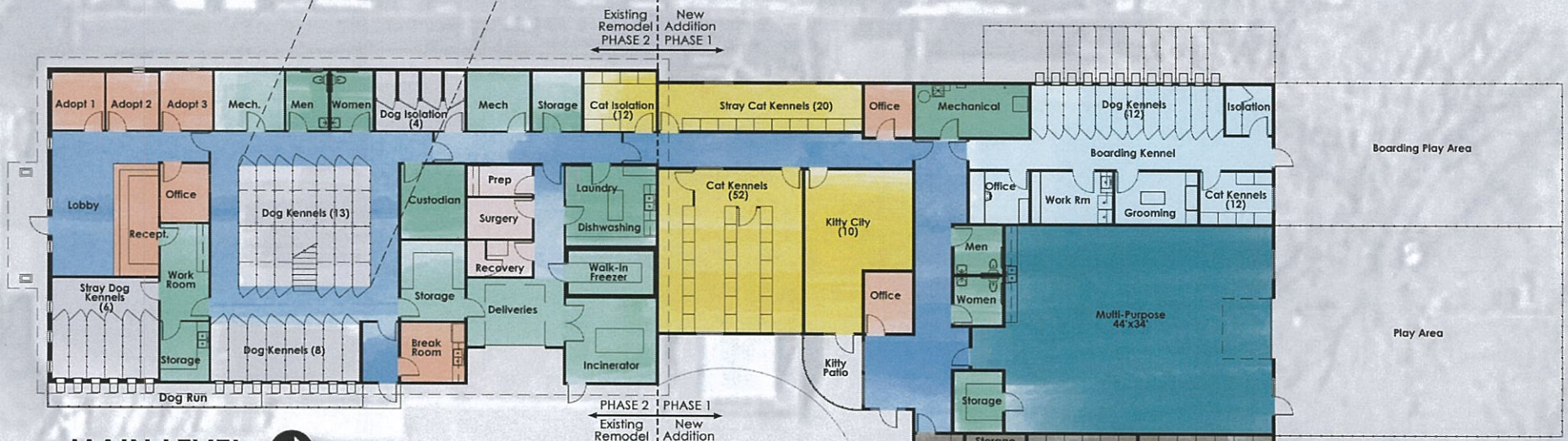

**MAIN LEVEL** 

	Dog Kennel Capacity	Cat Kennel Capacity
Adoption	34	62
Stray	6	20
Isolation	4	12
Boarding	12	12
Overflow	7	20
<b>TOTALS</b>	<b>63</b>	<b>126</b>





Souris Valley Animal Shelter Facility Masterplan  
Minot, North Dakota



## Souris Valley Animal Shelter Addition & Remodel

Minot, North Dakota		Design Phase: Preliminary	3/29/2017
New Construction area	6,611 sf		
Remodel area	5,280 sf		
		Low	High
<b>Phase 1 - New Construction</b>		<b>\$ 1,322,200.00</b>	<b>\$ 1,487,475.00</b>
<i>Estimated cost per sq. ft.</i>		\$200	\$225
<b>Phase 2 - Remodel</b>		<b>\$ 660,000.00</b>	<b>\$ 792,000.00</b>
<i>Estimated cost per sq. ft.</i>		\$125	\$150
<b>Phase 1 - Site Development</b>		<b>\$ 150,000.00</b>	<b>\$ 200,000.00</b>
<b>Total Estimated Construction Cost</b>		<b>\$ 2,132,200.00</b>	<b>\$ 2,479,475.00</b>
<i>Contingency</i>	10%	\$ 213,220.00	\$ 247,947.50
<i>Site Survey, Soil Boring, Testing, &amp; Report</i>	LS	\$ 15,000.00	\$ 15,000.00
<i>A-E Fees (% of total construction cost)</i>	7%	\$ 149,254.00	\$ 173,563.25
<i>Furnishings, Furniture, &amp; Equipment</i>	LS	\$ 400,000.00	\$ 400,000.00
<b>Estimated Project Cost</b>		<b>\$ 2,909,674.00</b>	<b>\$ 3,315,985.75</b>

**General Estimate Note:** These opinions of estimated costs are based on preliminary designs and not on completed bidding documents. It represents our opinion of construction costs and is based on our previous experiences of past and current construction costs in this area. It does not take into consideration exact materials and quantities required by a complete design, changes in future market conditions, or unforeseeable problems discovered at the time of construction. This estimate of cost is in 2016/2017 dollars. Actual bid prices will vary.

# COMMUNITY DEVELOPMENT COMMITTEE APPLICATION AND REQUEST FORM FOR USE OF SALES TAX PROCEEDS FOR COMMUNITY FACILITIES

## INTRODUCTION

Pursuant to Ordinance No. 4380 of the Minot Code of Ordinances, the City of Minot may make proceeds available from the city sales tax for purposes of upgrading, remodeling and constructing community facilities. These community facilities, for example, may be constituted by arenas, auditoriums, and facilities for conventions, tourist and spring events. Community facilities must meet one of the following three categories in order to be eligible for possible funding: (1) community facilities owned directly by the City of Minot; (2) community facilities owned directly by another county, city, township, city park district, school district, or other political subdivision of the state of North Dakota, including any agency, board, or institution of the State of North Dakota, and for which entities an appropriate Joint Powers Agreement has been lawfully executed between the City of Minot and the applicable entity; and (3) community facilities of private non-profit entities with which the City of Minot has authority to engage in with respect to a lawful business or enterprise under North Dakota law meeting a public purpose and for which an independent and applicable implementing Ordinance has been passed by the City, and which lawful business or enterprise is predicated upon subsequent written agreement sufficiently detailed to ensure supervisory controls and measurable analysis that the public purpose is being met.

The filing of an application or request form is not intended to guarantee an award or granting of sales tax proceeds to an applicant. The City of Minot reserves the right to approve or reject applications and projects on a case-by-case basis, taking into consideration established policies, project criteria, and demand on City services and finances in relation to the potential benefits from the project. In the consideration of submitted applications, the City will address the specific and unique needs of the community as a whole and will review the submitted applications in terms of serving the best interests of the community. Approval or denial of one project is not intended to set precedence for approval or denial of another project. The City of Minot shall also consider whether funding of an identified project results in unfair advantage or constitutes unfair competition, if applicable, with similar competitors or other like businesses.

The City of Minot may also request additional information, which is deemed necessary in the consideration and determination of a submitted application. Finally, applicants should not that all information submitted with respect to an application or request for sales tax proceeds in the construction, enhancement or improvement of community facilities, is subject to public disclosure, and that the City does not guarantee the confidentiality of the information submitted in the application process.

---

**APPLICATION/REQUEST**

Name of Organization/Facility:

YWCA Minot

Address: 205 3rd ave SE Minot, ND 58701

Contact Person/Spokesperson

Name: Ashley Boyd

Telephone No: 701-838-1812

Address: 205 3rd ave SE

Minot, ND 58701

Telephone: No: 701-838-1812

---

Type of Organization/Facility:

City/Public

Private Non/Profit

Another Governmental Entity

List of Applicant's Governing Board/Supervisor: Lorena Starkey, 2301 Landmark Drive North West  
Minot, ND 58703  
(Name/Address) Chelsea Gleich, 205 3rd ave SE Minot, ND 58701  
Ann Olson, 205 3rd ave SE Minot, ND 58701

---

Physical Location of Project: YWCA Shelter: 205 3rd ave SE Minot, ND 58701

---

Please describe this project and its benefits, and also explain how it relates to the community of Minot (For example, a description of the project or service; an outline of the project goals and intended results; a description of the economic impact of the project on the community; a projected time table for completion of the project; an explanation of how the City of Minot will benefit from the expenditure of sales tax proceeds for the project or service; and an explanation of how the outcome or success of the project will be evaluated or measured.)

See attached documents

---

If available, please describe and attach diagrams, or schematic designs of the requested project:

See attached documents

---

Specific amounts requested from the City of Minot and dates requested:

\$5,000.00

---

Describe any alternative sources of funding, other than the City of Minot, which will be pursued with respect to this project (also please indicate whether those sources are presently confirmed or tentative funding sources)

Minot Sertoma and Verendrye Electric have contributed funding for this project totaling \$7500.00. We have also solicited funding from Coca Cola .

---

Please list any other information, which the applicant believes, should be considered by the City of Minot in the determination of this request.

YWCA Minot is a great resource for the women and children we serve, but as an organization we always strive to achieve more. The "Fresh Start" program will enable us to serve those who do not qualify for our program or are unwilling to stay in the shelter. Its impact is unlimited. Additionally, the ability to serve our handicapped clients better will improve the success rates for the women staying in the shelter who have a physical disability.

---



**CERTIFICATION OF APPLICATION**

The undersigned hereby certifies that both they and the entity listed in this application, and the specific request herein for the use of sales tax proceeds for community facilities, does not, and will not discriminate in its plans, programs, and activities on the basis of race, color, national, origin, creed, religion, age, sex, handicap or any other basis which has been declared as discriminatory by federal or state cases or law.

Date: 4-24-2017

Signature: Abby Boyel

(Title/Position): Resident Manager

## Community Facilities Application Questions

1. Please describe this project and its benefits, and also explain how it relates to the community of Minot

YWCA Minot is seeking funding to convert our main floor restroom into a handicapped accessible bathroom, and to create a new program called "Fresh Start."

YWCA Minot is located in a 3 story building, and can house 17 homeless women and children at a time. Currently, 5 of our 6 homeless shelter rooms are in our basement and our handicapped accessible room is on the main floor. The problem that we encounter when we house a handicapped client is that the shelter's showering facility is on the basement level, and going down stairs can be hazardous or even impossible for a handicapped person. While we do have a restroom on the main floor, it is not equipped with the necessary features to serve our disabled clients. We hope to change that to better meet the needs of everyone who comes through our doors. With support, we intend to renovate the main floor restroom to include a handicapped accessible shower, a shower bench, and support rails.

In addition to this upgrade improving the lives of our handicapped clients, it will also be an opportunity to extend our community outreach. YWCA Minot is a zero-tolerance drug and alcohol shelter. If a person has any illegal substances in their system, they are not permitted to stay at the shelter until they are clean. While we do this to protect our clients, we recognize that these women and children need help too. That is why we intend to open our doors to the women and children in the Minot community during business hours to allow them to take a shower, meet with our staff, and get access to toiletries and clothing. This new service has been named the "Fresh Start" program. This is because we believe that simply being freshly showered may enable some of these women to pick up their lives, find jobs, and be a more marketable person in the community. Everyone deserves a "fresh start."

Because of the age of the building and the fact that we will have to re-work the layout of the restroom, we expect to pay up to \$14,000 dollars. It is our hope that we can stay closer to \$10,000. This number includes a new handicap accessible shower with accessories (safety bars and shower seats as necessary), plumbing changes, potential building related issues, and contractor fees. It is our goal to complete the project in the 2017 year, but understand that it may take longer.

# HIGHT CONSTRUCTION

*Experience Built Into  
Every Project*

PO Box 458 | 21 2<sup>nd</sup> Street SW | Minot, ND 58702 | Ph: (701)839-5819 | Fax: (701)839-1094

April 24, 2017

Lauren Moore – Executive Director [Email: laurenmooreywca@gmail.com]  
YWCA Minot  
205 3<sup>rd</sup> Ave SE  
Minot, ND 58701

Re: Construction proposal to add new shower into existing bathroom

Dear Lauren:

Thank you for allowing us to submit this proposal for your proposed addition of a new shower unit at the YWCA location in Minot. We appreciate the opportunity. We have based our proposal on the plans/plan specifications attached and Hight Construction will provide all labor, materials, equipment and supervision necessary to complete the project per the scope of work outlined below. All work will be performed according to North Dakota and City of Minot building and dwelling codes and ordinances.

**Summary Scope of Work (included in proposal):**

- General requirements commonly associated with construction such as insurances, supervision, small tools, equipment, vehicles, fuel, safety/OSHA adherence, office administration/billing, warranty/closeout procedures and as-built/operation and maintenance information as applicable to our scope of work.
- Architectural work including permitting and approvals from the City of Minot.
- Selective demolition as required for our new construction including removal/relocate of toilet, grab bars, wall cabinet & towel dispenser.
- Construct mini-ramp with feathered concrete/aluminum cap for shower stall access.
- Carpentry including framing new 2 x 4 wall - 78" high to enclose new shower unit.
- Re-install wall cabinet, grab bars & towel dispenser.
- Gypsum board work for new wall plus patching where needed (i.e. old towel dispenser location).
- Painting/finishing of new walls and patched areas including general touch-up.
- Mechanical (plumbing) work including furnish & installation of new shower stall complete fixtures/accessories and the running of new supply/waste for relocated toilet installation
- No electrical work is included.

**Base bid for all work above: \$ 13,000**

**Notes & Exclusions**

- No work other than that expressly noted above
- This proposal is valid for 60 days from the above date at which time it may be withdrawn or extended at the sole discretion of Hight Construction, LLC.

Please call with any questions or to proceed with work. Thanks very much and have a great Christmas.

Sincerely yours,

# YWCA SHOWER ADDITION

## MINOT, NORTH DAKOTA



**HIGHT**  
CONSTRUCTION

HIGHT CONSTRUCTION, LLC  
PO BOX 458, MINOT, ND 58701  
701.839.8119 www.hightconstruction.com

YWCA SHOWER ADDITION

205 3RD AVENUE SE  
MINOT, NORTH DAKOTA 58701

PROJECT # 2016-04  
ISSUE DATE 12/21/16  
DESIGNED BY MFB  
CREATED BY MFB

REVISIONS

CONSTRUCTION DOCUMENTS

TITLE SHEET

SHEET NUMBER

**T1.0**

**DESIGN-BUILD FIRM**  
HIGHT CONSTRUCTION, LLC  
PO BOX 458, MINOT ND 58702-0458  
JAY P. HIGHT, PRESIDENT  
MICHAEL W. OAKLEAF, ARCHITECT  
ph: 701.839.5819 jhight@srt.com  
fx: 701.839.1094 hightarch@srt.com

©2016 by Hight Construction, LLC. All rights reserved.

THIS WORK, INCLUDING ALL DESIGNS, DRAWINGS, AND RENDERINGS CONTAINED HEREIN, IS THE INTELLECTUAL PROPERTY OF THE AUTHOR, Hight Construction, LLC.  
THIS WORK, IN WHOLE OR IN PART, IS PROTECTED AGAINST UNAUTHORIZED USE OR REPRODUCTION BY COPYRIGHT LAW. ANY USE OF THIS WORK, IN WHOLE OR IN PART, BY ANY PERSON OR ENTITY FOR USE OTHER THAN THAT CONTAINED HEREIN MUST BE PRECEDED BY WRITTEN CONSENT FROM THE AUTHOR.

### INDEX OF DRAWINGS

T 1.0	TITLE SHEET
A 2.0	DEMOLITION & REMODEL FLOOR PLANS
A 3.0	BATHROOM ELEVATIONS



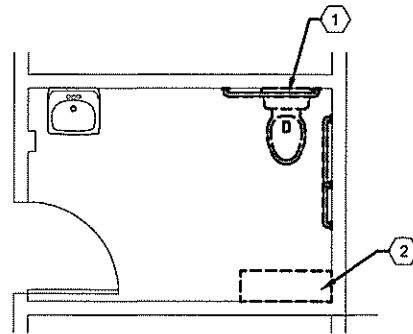



1 DEMOLITION PLAN  
A2.0 SCALE: 1/4" = 1'-0" 

DEMOLITION KEY NOTES:

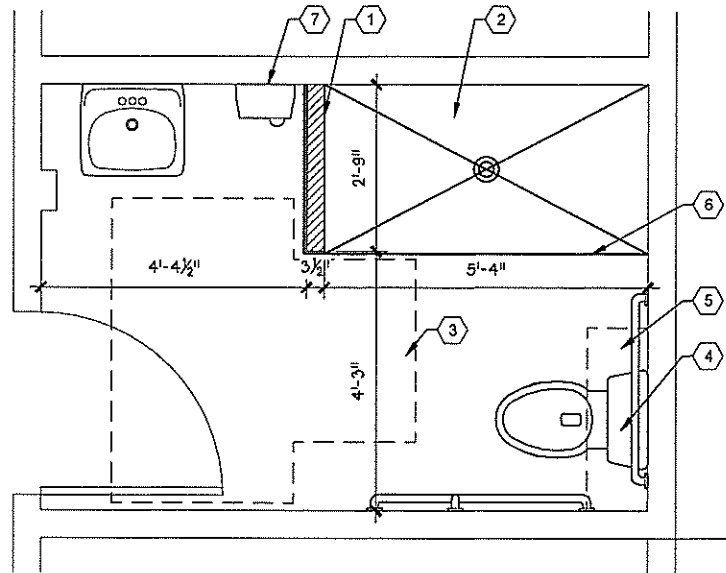
- ① REMOVE TOILET AND GRAB BARS FOR NEW BATHROOM CONFIGURATION.
- ② REMOVE WALL CABINET FOR NEW LOCATION.



2 MAIN FLOOR PLAN  
A2.0 SCALE: 1/2" = 1'-0" 

REMODEL FLOOR PLAN KEY NOTES:

- ① 78" TALL WOOD FRAMED WALL WITH 2X4'S @ 16" O.C.
- ② NEW H.C. ACCESSIBLE SHOWER USING WR 6030 OR SIMILAR TO FIT.
- ③ T-SHAPED TURNING SPACE.
- ④ RELOCATED TOILET AND GRAB BARS.
- ⑤ RELOCATED WALL CABINET.
- ⑥ MINI-RAMP TRANSITION USING ARDEX FEATHER FINISH OR COMPARABLE PRODUCT.
- ⑦ REPOSITION PAPER TOWEL DISPENSER AWAY FROM NEW WALL.
- ⑧ PATCH WALLS AS NECESSARY.

PROJECT #	2010-04
ISSUE DATE	12-11-2010
DRAWN BY	MWV
CHECKED BY	MWV

REVISIONS

CONSTRUCTION DOCUMENTS

REMODEL PLAN

SHEET NUMBER  
**A2.0**

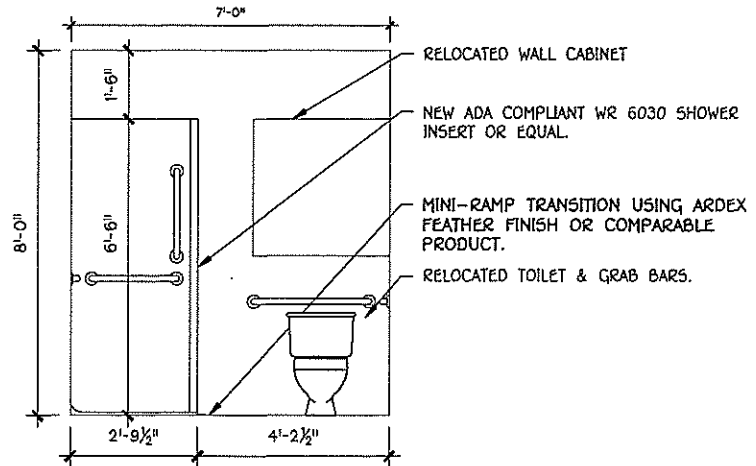
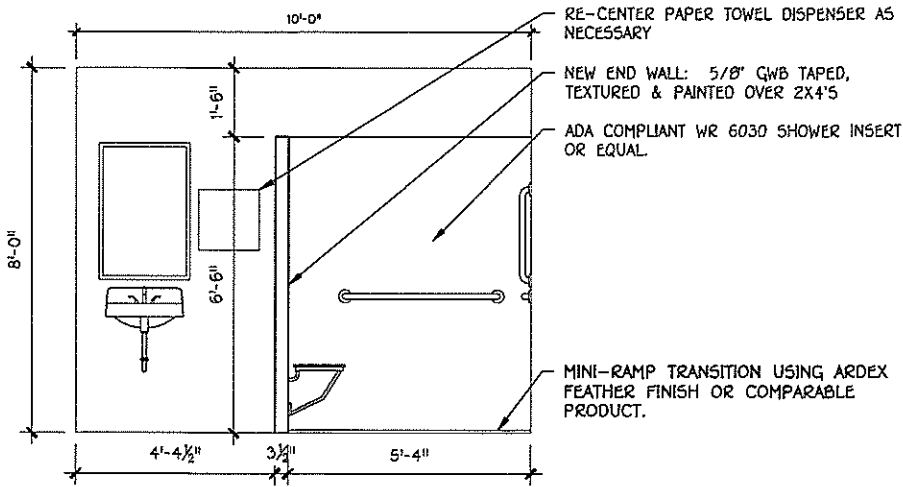

1 ELEVATION - NORTH WALL

A3.0 SCALE: 3/8 = 1'-0"

2 ELEVATION - EAST WALL

A3.0 SCALE: 3/8 = 1'-0"

**HIGHT CONSTRUCTION**

HIGHT CONSTRUCTION, LLC  
 1000 S. UNIVERSITY AVENUE  
 MINOT, NORTH DAKOTA 58701  
 701.837.2610 www.hightconstruction.com

**YWCA SHOWER ADDITION**

205 3RD AVENUE SE  
 MINOT, NORTH DAKOTA 58701

PROJECT #	0119-04
ISSUE DATE	12.21.2016
DRAWN BY	SPW
CHECKED BY	SPW

REVISIONS

CONSTRUCTION DOCUMENTS

ELEVATIONS

SHEET NUMBER

**A3.0**